



FIVE REASONS

To Demand Genuine Senco Fasteners.

1. Less Broken Collation
2. Fewer Tool Jams
3. More Completed Drives
4. Highest Withdrawal Values
5. Absolute Code Compliance.

SENCO[®]

Performance. Power.
Productivity.[™]

SENCO Fastener Identification Charts

Fastener Identification

7-DIGIT STAPLE CODING SYSTEM

1st DIGIT				2nd & 3rd DIGIT		4th DIGIT	5th DIGIT	6th DIGIT	7th DIGIT	
Crown	Width	Thk.	Ga.	Leg Length		Point	Wire Chem. & Fin.	Finish	Features	
A	3/16	.030	.0215	22	01	1/8 (3mm)	A Blunt	A*Galv. Std. Tensile	A Clear Glue	B Bandline
B	1/2	.030	.0215	22	02	5/32 (4mm)	B Chisel	B Galv. High Tensile	B Sencote	C Container
C	3/8	.030	.0215	22	03	3/16 (5mm)	C Inside Chisel	C Liq. Fin. Std. High Ten.	C Painted & Sencote	G Glue
D	3/16	.030	.0215	22	04	1/4 (6mm)	D Outside Chisel	D Liq. Fin. Ult. High Ten.	D Ptd. & Sencote	J Made in Japan
E	3/16	.050	.019	20	05	5/16 (8mm)	E Easy Clinch	E Liq. Fin. Low Tensile	E Coated	N Carton count change
F	1/2	.050	.019	20	06	3/8 (10mm)	F Divergent	F Senclamp	F To be Painted	P Bulk pack
G	3/8	.045	.023	20	07	7/16 (11mm)	G Outside Chisel Div.	G Stainless Steel	G Extractable	R Retail pack
H	7/16	.050	.019	20	08	1/2 (12mm)	H Cross Cut Chisel	H Stainless Steel Hi. Ten. AISI-304		S Special strong glue
J	7/16	.075	.023	18	09	9/16 (14mm)	J Cross Cut Chisel Div.	J Monel		T Taped strips
K	1/4	.045	.030	19	10	5/8 (16mm)	K Spear	K Steel Core Aluminum		V Angular strips
L	1/4	.050	.044	18	11	3/4 (19mm)	L Chisel Div.	L Steel Core Bronze		Z Coiled Staples
M	3/8	.050	.044	18	12	7/8 (22mm)	M Self Clinch	M Aluminum		
N	7/16	.062	.055	16	13	1 (25mm)	N Sharp Chisel	N Bronze		
O	7/16	.058	.050	17	14	1-1/8 (28mm)	R Step	P Reg. Galv. (flash) or Greater		
P	1	.062	.055	16	15	1-1/4 (32mm)		Q Class 1 Galv. Std. Tensile		
Q	7/16	.074	.067	15	16	1-3/8 (35mm)		R Brt. Basic Std. Tensile		
R	3/16	.045	.030	19	17	1-1/2 (38mm)		S Special Hardened Steel		
S	7/16	.083	.075	14	18	1-5/8 (41mm)		U Stainless Steel, AISI-316		
T	1	.086	.070	14	19	1-3/4 (44mm)				
U	1 1/4	.075	.035	14	20	1-7/8 (48mm)				
W	3/16	.032	.025	21	21	2 (50mm)				
X	1	.082	.020	25	22	2-1/8 (54mm)				
Y	7/16	.082	.020	25	23	2-1/4 (56mm)				
Z	Special Fasteners				24	2-3/8 (60mm)				
1	1-3/8	.075	.035	14	25	2-1/2 (63mm)				
					26	2-3/4 (70mm)				
					27	3 (76mm)				
					28	3-1/4 (82mm)				
					29	3-1/2 (90mm)				

Example: **G08BAA**
G = 3/8" Crown, .045" Width, .023" Thickness
08 = 1/2" Leg Length
B = Chisel Point
A = Galvanized Standard Tensile
A = Plain



*Class 1 Galvanized 5th digit "A" for 1st digit staple series N, P, Q, S"

8-DIGIT NAIL CODING SYSTEM

1st Digit	2nd Digit	3rd & 4th	5th Digit	6th Digit	7th Digit	8th Digit	
Gauge Inch	Head/Shank Form	Length	Point	Wire Chem. & Fin.	Finish	Features	
A 18	.039	A Brad, Smooth	08 1/2 (12mm)	A Diamond	A Reg. Galv. Std. Ten.	A Plain	A Coil, flat wnd., angular wire, 6.0mm Euro, bulk pack
B 12.5	.099	C Flat, Smooth	10 5/8 (16mm)	B Blunt Diamond	B Reg. Galv. Olive Drab	B Sencote	B Coil, flat wound, straight wire, carrier strip
C 23	.0267	D Flat, Smooth FRH	11 3/4 (19mm)	C Blunt	D WeatherX™ 2 Galv.	C Painted	C Coil, flat wound, angular wire, carrier strip
D 15	.072	E Flat, Ring Shank	12 7/8 (22mm)	E Chisel	E Hot Dip Galv. Heat Trtd.	D Painted & Sencote	D FRH-paper tape, 34" collation
E 13	.092	F Flat, Screw Shank	13 1 (25mm)	F Blunt Chisel	G Stainless Stl. AISI-304	E Coated by Vendor	F Coil, flat wound, angular wire, 8.2mm spacing
F 12.62	.097	G Conical, Ring Drywall FRH	14 1 1/8 (28mm)	G Semi-Blunt	H Bright Basic Ht. Trtd.	F Sencoted-Full Cov.	G Coil, flat wound, straight wire
G 11.5	.113	H T-head, Smooth	15 1 1/4 (32mm)	X Special	I Reg. Galv. Ht. Trtd.	S New Glue	H Coil, flat wound, angular wire, 7.0mm spacing
H 11	.120	J Flat, Smooth O/S FRH	16 1 3/8 (35mm)		J Hot Dip Galv. Med. Carbon		J Special head feature
I 11	.124	K Flat, Screw O/S FRH	17 1 1/2 (38mm)		M Aluminum		K Special strip length
J 12	.105	L Flat, Ring FRH	18 1 5/8 (41mm)		P Bright Basic Std. Ten.		L FRH plastic collation 7.5mm spacing
K 10.25	.131	M Flat, Ring O/S FRH	19 1 3/4 (44mm)		Q Bright Basic Med. Carbon		N Carton count change
L 10.25	.135	N Flat, Smooth U/S FRH	20 1 7/8 (48mm)		R Reg. Galv. Yel. Chromate		P Bulk pack or high load coil
M 9	.148	R Duplex Head	21 2 (50mm)		S Hot Dip Galv. 43 Micron		Q 300 DI. head drywall nail
N 8	.162	S Flat, Ring, Dome, FRH	22 2 1/8 (54mm)		T "Flash" Galv. or Greater		R Retail packaging
P 13.5	.086	T Full Length Step Ring	23 2 1/4 (56mm)		U Stainless Stl. AISA-316		S FRH-Strip, plastic collation
R 16	.063	U Bugle, Smooth FRH	24 2 3/8 (60mm)		X Hot Dip Galv. 50 Micron		T FRH, 20" paper tape collation
S 13.75	.082	V Bugle, Ring FRH	25 2 1/2 (63mm)		Z Bronze		U Coil, inverted con. wnd., angular, plastic collation
T 6	.181	WL-head "Cleat" Flooring Nail	26 2 3/4 (70mm)	3rd & 4th continued	FRH = Full Round Head		V Coil, con. wnd., angular, wire collation
U 14	.08	X Med. Head Brad	27 3 (76mm)	59 90mm (3-9/16)	O/S = Oversize Head		W Con. wnd., straight wire collation, 8.2mm spacing
W 11	.122	Y Slight Head Brad	28 3 1/4 (82mm)	60 100mm (4)	U/S = Undersize Head		X Three-quarter strip length
Z Special Fast.	Z Headless Pin	29 3 1/2 (90mm)	61 110mm (4-5/16)	62 115mm (4-1/2)	Example: KC27APB		Y Coil, inverted con. wnd., straight plastic collation
1 11.75	.110	1 Flat, 1/3 Ring	30 2 5/8 (66mm)	63 120mm (4-3/4)	K = .131"		Z Coil, con. wnd., straight wire 5.5 & 6.5mm spacing
2 7	.177	2 Flat, 1/3 Screw	31 4 (102mm)	64 125mm (4-7/8)	C = Flathead, Smooth Shank		3 Finish nail / alternate angle collation
3 17	.054	3 Dome, Smooth, O/S	32 4 1/4 (108mm)	65 130mm (5-1/8)	27 = 3" nail		4 FRH nail, plastic collation 17"
		4 Dome, Ring O/S	33 4 1/2 (114mm)	66 135mm (5-5/16)	A = Diamond Point		
		5 Offset FRH, Smooth	34 5 (127mm)	67 140mm (4-1/2)	P = Bright Basic, Standard Tensile		
		6 Offset FRH, Ring	46 35mm (1-3/8)	68 145mm (5-3/4)	B = Sencoted		
			47 40mm (1-9/16)	69 150mm (6)			
			49 45mm (1-3/4)	70 160mm (6-1/2)			
			51 50mm (2)	74 2 7/8 (73mm)			
			52 55mm (2-1/8)	85 85mm (3-5/16)			
			54 60mm (2-3/8)	95 95mm (3-3/4)			
			55 65mm (2-9/16)				
			56 70mm (2-3/4)				
			57 75mm (3)				
			58 80mm (3-1/8)				



Finish Nails 15 Ga. 34° Angled

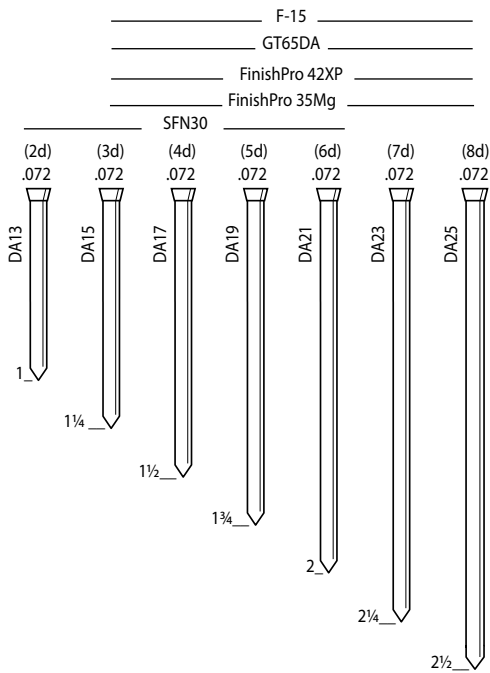

SENCO® 15 Ga. 34° Angled Strip Finish Nails

Furniture and cabinets, molding and trim, baseboard, chair rail, doors and window casings

Length	Item Code	Box Count	Point	Finish	Coating	Package
1	DA13EPBN	4.M	Chisel	Bright	Sencote	Box
1¼	DA15EPBN	4.M	Chisel	Bright	Sencote	Box
1½	DA17EPBN	4.M	Chisel	Bright	Sencote	Box
1¾	DA19EPBN	4.M	Chisel	Bright	Sencote	Box
2	DA21EPBN	4.M	Chisel	Bright	Sencote	Box
2¼	DA23EPBN	4.M	Chisel	Bright	Sencote	Box
2½	DA25EPB	3.M	Chisel	Bright	Sencote	Box
1½	A301500	0.7M	Chisel	Bright	Sencote	Clamshell
1¾	A301750	0.7M	Chisel	Bright	Sencote	Clamshell
2	A302000	0.7M	Chisel	Bright	Sencote	Clamshell
2½	A302500	0.7M	Chisel	Bright	Sencote	Clamshell
1¼	DA15EABN	4.M	Chisel	Galv	Sencote	Box
1½	DA17EABN	4.M	Chisel	Galv	Sencote	Box
1¾	DA19EABN	4.M	Chisel	Galv	Sencote	Box
2	DA21EABN	4.M	Chisel	Galv	Sencote	Box
2½	DA25EAB	3.M	Chisel	Galv	Sencote	Box
2	A302009	0.7M	Chisel	Galv	Sencote	Clamshell
2½	A302509	0.7M	Chisel	Galv	Sencote	Clamshell
2	DA21EGBN	2.M	Chisel	Stainless	Sencote	Box
2½	DA25EGB	1.2M	Chisel	Stainless	Sencote	Box
1¼	DA15AIA	4.M	Diamond	Hardened*	Plain	Box
1½	DA17AIA	4.M	Diamond	Hardened*	Plain	Box
1¾	DA19AIA	4.M	Diamond	Hardened*	Plain	Box

*Hardened reg. galv. heat treated 15 gauge for steel stud and trim application

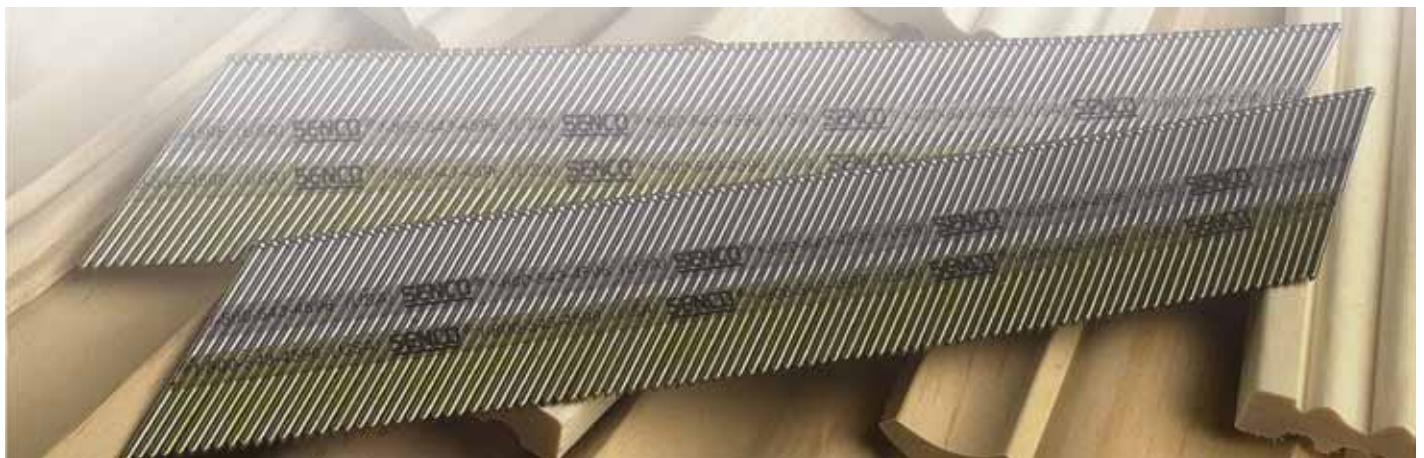

Finish Nails 16 Ga. Straight and 20° Angled Strip

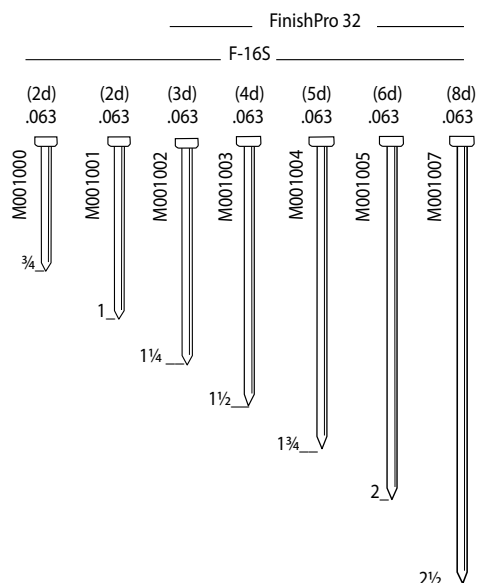

SENCO® 16 Ga. Straight Strip Finish Nails

Furniture and cabinets, molding and trim, baseboard, chair rail, window casings and upholstery trim panels

Length	Item Code	Box Count	Head	Point	Finish	Coating	Package
3/4	M001000	2.M	T-head	Chisel	Galv	Sencote	Box
1	M001001	2.M	T-head	Chisel	Galv	Sencote	Box
1 1/4	M001002	2.M	T-head	Chisel	Galv	Sencote	Box
1 1/2	M001003	2.M	T-head	Chisel	Galv	Sencote	Box
1 3/4	M001004	2.M	T-head	Chisel	Galv	Sencote	Box
2	M001005	2.M	T-head	Chisel	Galv	Sencote	Box
2 1/2	M001007	2.M	T-head	Chisel	Galv	Sencote	Box
1	A401009	1.2M	T-head	Chisel	Galv	Plain	Clamshell
1 1/4	A401259	1.2M	T-head	Chisel	Galv	Plain	Clamshell
1 1/2	A401509	0.7M	T-head	Chisel	Galv	Plain	Clamshell
1 3/4	A401759	0.7M	T-head	Chisel	Galv	Plain	Clamshell
2	A402009	0.7M	T-head	Chisel	Galv	Plain	Clamshell
2 1/2	A402509	0.7M	T-head	Chisel	Galv	Plain	Clamshell
Variety	A409809	0.8M	T-head	Chisel	Galv	Plain	Clamshell



16 Ga. Straight Strip

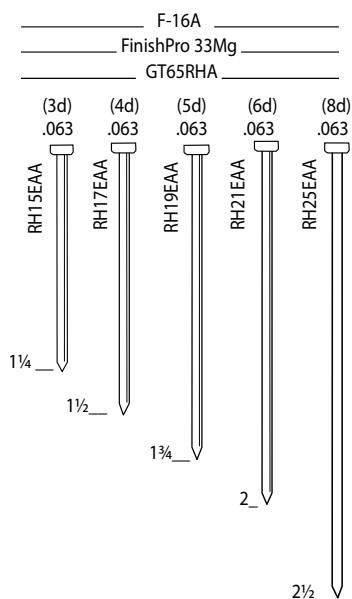

SENCO® 16 Ga. 20° Angled Strip Finish Nails*

Length	Item Code	Box Count	Head	Point	Finish	Coating	Package
1 1/4	RH15EAA	2.M	T-head	Chisel	Galv	Sencote	Plastic Box
1 1/2	RH17EAA	2.M	T-head	Chisel	Galv	Sencote	Plastic Box
1 3/4	RH19EAA	2.M	T-head	Chisel	Galv	Sencote	Plastic Box
2	RH21EAA	2.M	T-head	Chisel	Galv	Sencote	Plastic Box
2 1/2	RH25EAA	2.M	T-head	Chisel	Galv	Sencote	Plastic Box

*NOTE: ONLY Fits 16 Gauge 20-Degree Finish Nailers



16 Ga. 20° Angled Strip

Finish Nails 18 - 23 Gauge

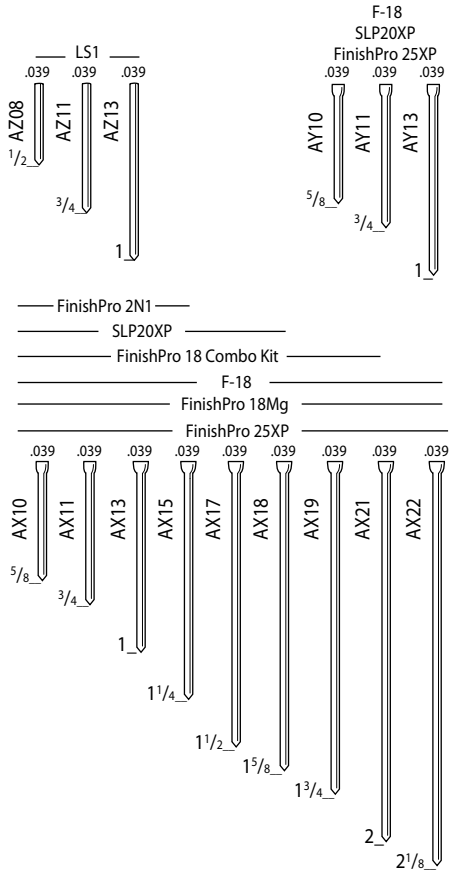

SENCO® 18 Ga. Straight Strip Brad Nails

Cabinets, decorative trim, picture frames and ornamentals

Length	Item Code	Box Count	Head	Point	Finish	Coating	Package
1/2	AZ08EAA	5.M	Headless	Chisel	Galv	Plain	Box
3/4	AZ11EAA	5.M	Headless	Chisel	Galv	Plain	Box
1	AZ13EAA	5.M	Headless	Chisel	Galv	Plain	Box
5/8	AY10EAA	5.M	Slight	Chisel	Galv	Plain	Box
3/4	AY11EAA	5.M	Slight	Chisel	Galv	Plain	Box
1	AY13EAA	5.M	Slight	Chisel	Galv	Plain	Box
5/8	AX10EAA	5.M	Medium	Chisel	Galv	Plain	Box
3/4	AX11EAA	5.M	Medium	Chisel	Galv	Plain	Box
1	AX13EAA	5.M	Medium	Chisel	Galv	Plain	Box
1 1/4	AX15EAA	5.M	Medium	Chisel	Galv	Plain	Box
1 1/2	AX17EAA	5.M	Medium	Chisel	Galv	Plain	Box
1 5/8	AX18EAA	5.M	Medium	Chisel	Galv	Plain	Box
1 3/4	AX19EAA	5.M	Medium	Chisel	Galv	Plain	Box
2	AX21EAA	5.M	Medium	Chisel	Galv	Plain	Box
2 1/8	AX22EAA	5.M	Medium	Chisel	Galv	Plain	Box

AZ = headless brad
 AY = slight-headed brad
 AX = medium-headed brad



18 Ga. Brads, Straight Strip

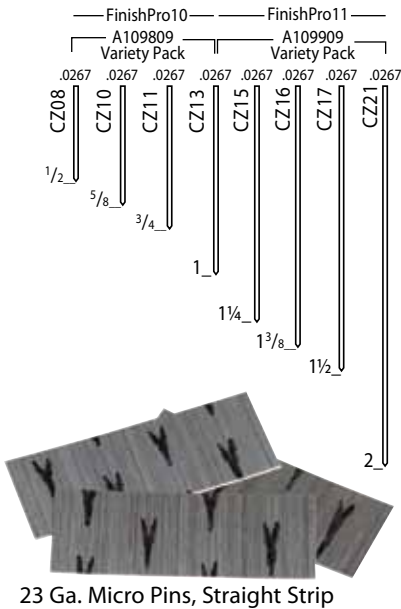

23 Ga. Micro Pins, Straight Strip

SENCO® 23 Ga. Straight Strip Micro Pins

Pins fasten the smallest of trim securely leaving a nearly invisible hole.

Length	Item Code	Box Count	Head	Finish	Coating	Package
1/2	A100509	2.6M	Headless	Galv	Plain	Clamshell
5/8	A100629	2.6M	Headless	Galv	Plain	Clamshell
3/4	A100759	2.6M	Headless	Galv	Plain	Clamshell
1	A101009	2.6M	Headless	Galv	Plain	Clamshell
1 1/4	A101259	2.6M	Headless	Galv	Plain	Clamshell
1 3/8	A101379	2.6M	Headless	Galv	Plain	Clamshell
1 1/2	A101509	2.6M	Headless	Galv	Plain	Clamshell
2	A102009	2.6M	Headless	Galv	Plain	Clamshell
Variety	A109809	2.5M	Headless	Galv	Plain	Clamshell
Variety	A109909	2.5M	Headless	Galv	Plain	Clamshell
1/2	CZ08EAA	15.5M	Headless	Galv	Plain	Box
5/8	CZ10EAA	15.5M	Headless	Galv	Plain	Box
3/4	CZ11EAA	15.5M	Headless	Galv	Plain	Box
1	CZ13EAA	15.5M	Headless	Galv	Plain	Box

Framing Nails 34° Clipped Head Smooth Shank

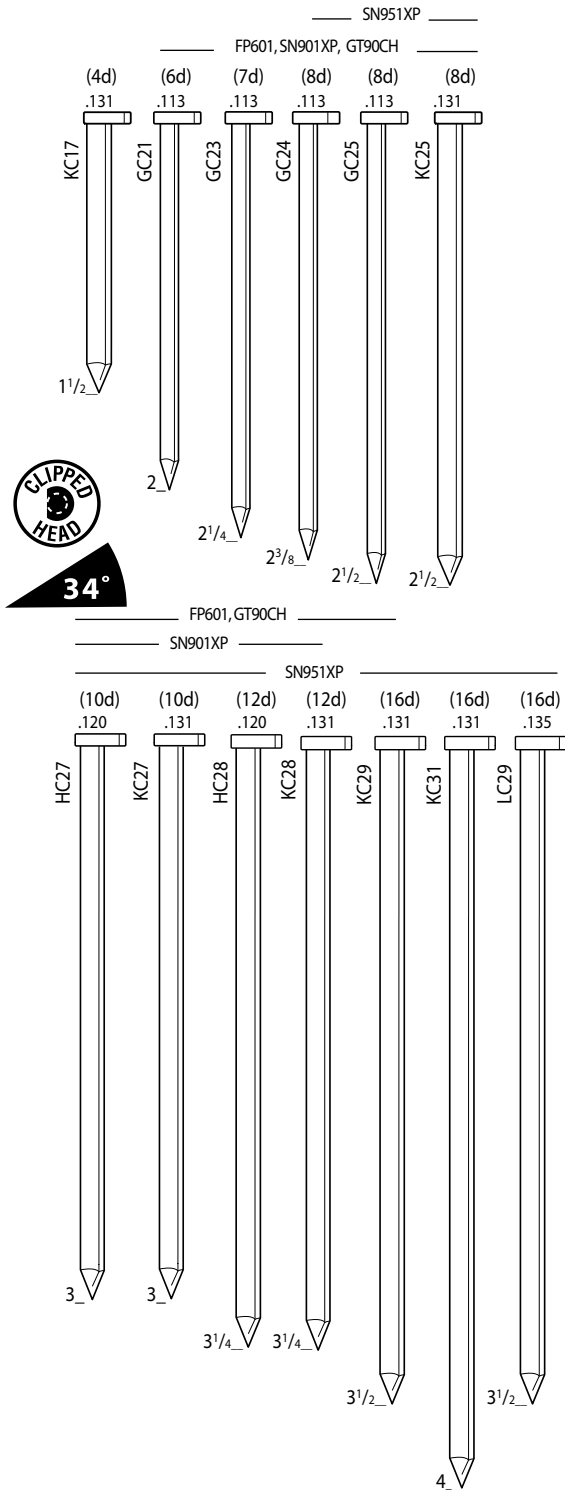

SENCO® 34° Smooth Shank Paper Tape Collated Nails

Framing, sheathing, subfloor, decks, trusses and pallets

Length	Item Code	Box Count	Point	Finish	Coating
1 1/2 x .131	KC17APBK	1.M	Diamond	Bright	Sencote
1 1/2 x .131	KC17AHBK	1.M	Diamond	Bt. Hardened	Sencote
2 x .113	M002080	2.M	Diamond	Bright	Sencote
2 x .113	GC21APBK	2.5M	Diamond	Bright	Sencote
2 1/4 x .113	GC23APBX	2.5M	Diamond	Bright	Sencote
2 1/4 x .113	GC23AHAK	1.M	Diamond	Bt. Hardened	Plain
2 3/8 x .113	GC24APBX	2.5M	Diamond	Bright	Sencote
2 1/2 x .113	GC25APBX	2.5M	Diamond	Bright	Sencote
2 3/4 x .120	HC26APBK	3.M	Diamond	Bright	Sencote
3 x .120	HC27APB	3.M	Diamond	Bright	Sencote
3 x .120	HC27APBX	2.5M	Diamond	Bright	Sencote
3 x .131	KC27APBX	2.5M	Diamond	Bright	Sencote
3 1/4 x .120	HC28APBX	2.5M	Diamond	Bright	Sencote
3 1/4 x .131	KC28APBX	2.5M	Diamond	Bright	Sencote
3 1/2 x .131	KC29APBX	2.5M	Diamond	Bright	Sencote
4 x .131	KC31APBK	2.4M	Diamond	Bright	Sencote
3 1/2 x .135	LC29APBK	3.M	Diamond	Bright	Sencote
2 x .113	GC21AABK	2.5M	Diamond	Galv	Sencote
2 3/8 x .113	GC24ASBK	2.M	Diamond	Hot Dip	Sencote
2 1/2 x .113	GC25AABKN	5.M	Diamond	Galv	Sencote
2 1/2 x .131	KC25AAB	5.M	Diamond	Galv	Sencote
3 x .120	HC27AABX	2.5M	Diamond	Galv	Sencote
3 x .131	KC27EDB	1.M	Chisel	WeatherX™2	Sencote
3 x .131	KC27ASBX	2.5M	Diamond	Hot Dip	Sencote
3 1/4 x .131	KC28ASBX	2.5M	Diamond	Hot Dip	Sencote
3 1/4 x .131	KC28AABX	2.5M	Diamond	Galv	Sencote
3 1/2 x .131	KC29ASBX	2.5M	Diamond	Hot Dip	Sencote
3 1/2 x .131	KC29AABX	2.5M	Diamond	Galv	Sencote
3 x .131	KC27AGBK	1.M	Diamond	Stainless	Sencote
3 1/4 x .131	KC28AGB	1.M	Diamond	Stainless	Sencote



Framing Nails 34° Clipped Head Ring & Screw Shank

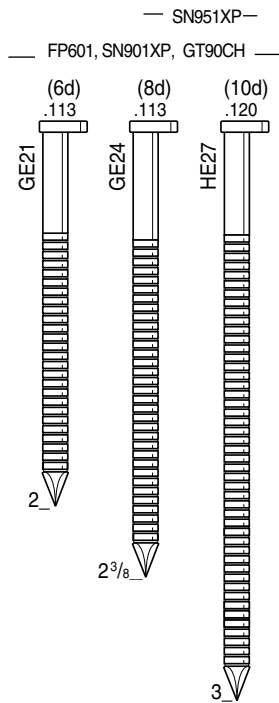

FP601, SN901XP, SN951XP



SENCO® 34° Ring Shank Paper Tape Collated Nails

Framing, sheathing, subfloor, decks, trusses and pallets

Length	Item Code	Box Count	Point	Finish	Coating
2 x .113	GE21APAK	2.M	Diamond	Bright	Plain
2 x .113	M002080	2.5M	Diamond	Bright	Plain
2 3/8 x .113	GE24APBX	2.5M	Diamond	Bright	Sencote
2 x .113	GE21AAAK	2.M	Diamond	Galv	Plain
2 x .113	GE21ASBK	2.M	Diamond	Hot Dip	Sencote
2 3/8 x .113	GE24AAAK	1.5M	Diamond	Galv	Plain
2 3/8 x .113	GE24AABX	2.5M	Diamond	Galv	Sencote
2 3/8 x .113	GE24ASBX	2.5M	Diamond	Hot Dip	Sencote
3 x .120	HE27AABX	2.5M	Diamond	Galv	Sencote
3 x .120	HE27ASBX	2.5M	Diamond	Hot Dip	Sencote
2 3/8 x .113	GE24AGBK	1.M	Diamond	Stainless	Sencote
3 x .120	HE27AGBK	1.M	Diamond	Stainless	Sencote

Clipped Head Strip Nails



SENCO® 34° Screw Shank Paper Tape Collated Nails

Framing, sheathing, subfloor, decks, trusses and pallets

Length	Item Code	Box Count	Point	Finish	Coating
3 x .120	HF27EPAK	3.1M	Chisel	Bright	Plain
3 x .120	HF27ESBK	2.M	Diamond	Hot-Dip	Sencote
3 x .120	HF27EDB	1.M	Chisel	WeatherX™2	Sencote
3 x .120	HF27AGBK	1.M	Diamond	Stainless	Sencote

Framing Nails 34° RoundStrip Ring & Smooth Shank

SENCO[®]

Performance. Power.
Productivity.™

RoundStrip™



A Round Head Framing Nail That Fits in Clipped Head Nailers.

Drive with the Senco[®] GT90CH, SN901XP, SN951XP, FramePro[®] 701XP and 751XP Clipped Head Framing Nailers. RoundStrip Nails offer an alternative fastening solution for your Clipped Head Nailers when a Round Head Nail is needed.

RoundStrip Nails offer the same advantages as the Clipped Head and more!

- 60 nails per strip, instead of only 28 in a 20° Round-Head strip, less time re-loading too.
- New weather-resistant tape, reduces flying debris and “flagging” found with plastic collated fasteners.
- Available in full strips and half length “HandyStrips”.
- No difference in price or carton count.
- Meets all national model building codes - ICC, IRC, UBC SBC, etc.
- Meets regional requirements for round head nails in framing and sheathing (tested in FL, NC and CA).

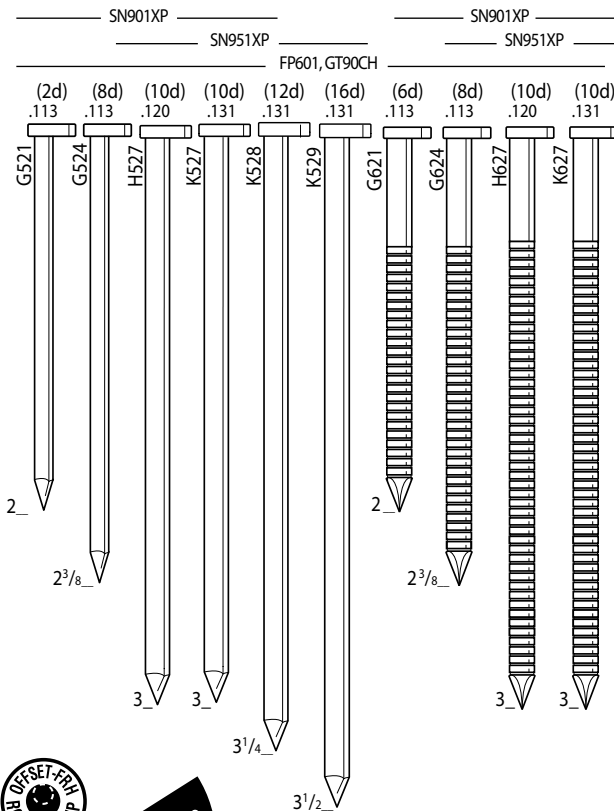

SENCO[®] RoundStrip™ 34° Smooth Round Head Nails

This design allows round head nails to be collated in a “nested” shank-to-shank 34° paper tape strip

Shank	Length	Item Code	Box Count	Point	Finish	Coating	Strip
Smooth	2 3/8 x .113	G524APBX	2.5M	Diamond	Bright	Sencote	HandyStrip
Smooth	3 x .120	H527APBX	2.5M	Diamond	Bright	Sencote	HandyStrip
Smooth	3 x .131	K527APBX	2.5M	Diamond	Bright	Sencote	HandyStrip
Smooth	3 1/4 x .131	K528APBX	2.5M	Diamond	Bright	Sencote	HandyStrip
Smooth	3 1/2 x .131	K529APBX	2.5M	Diamond	Bright	Sencote	HandyStrip
Smooth	2 x .113	G521ASBK	2.M	Diamond	Hot Dip	Sencote	HandyStrip
Smooth	2 3/8 x .113	G524ASBX	2.5M	Diamond	Hot Dip	Sencote	HandyStrip
Smooth	3 x .120	H527ASBX	2.5M	Diamond	Hot Dip	Sencote	HandyStrip
Smooth	3 x .131	K527ASBX	2.5M	Diamond	Hot Dip	Sencote	HandyStrip
Smooth	3 1/4 x .131	K528ASBX	2.5M	Diamond	Hot Dip	Sencote	HandyStrip

SENCO[®] RoundStrip™ 34° Ring Round Head Nails

Ring	Shank	Length	Item Code	Box Count	Point	Finish	Coating	Strip
Ring	2 3/8 x .113		G624APBX	2.5M	Diamond	Bright	Sencote	HandyStrip
Ring	3 x .120		H627APBX	2.5M	Diamond	Bright	Sencote	HandyStrip
Ring	2 x .113		G621ASBK	2.M	Diamond	Hot Dip	Sencote	HandyStrip
Ring	2 3/8 x .113		G624ASBX	2.5M	Diamond	Hot Dip	Sencote	HandyStrip
Ring	3 x .120		H627ASBX	2.5M	Diamond	Hot Dip	Sencote	HandyStrip
Ring	3 x .131		K627ASBX	2.5M	Diamond	Hot Dip	Sencote	HandyStrip



34°

Metal Connector

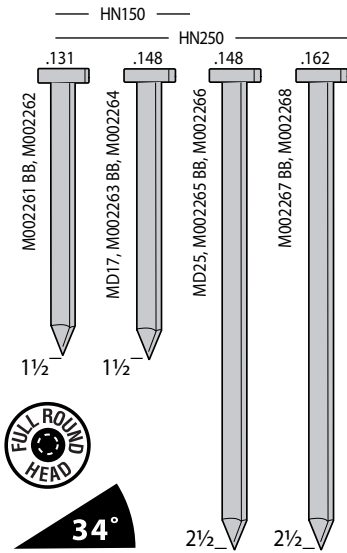

SENCO® 34° Metal Connector Paper Tape Collated Nails

Joist hangers, foundation anchors, seismic and hurricane straps and ties, standard tensile, non-hardened nails

Length	Item Code	Box Count	Point	Finish	Coating	Collation
1½ x .131	M002261	2.M	Diamond	Bright	Plain	34° Paper Tape, Strip
1½ x .148	M002263	2.M	Diamond	Bright	Plain	34° Paper Tape, Strip
2½ x .148	M002265	1.5M	Diamond	Bright	Plain	34° Paper Tape, Strip
2½ x .162	M002267	1.2M	Diamond	Bright	Plain	34° Paper Tape, Strip
1½ x .131	M002262	2.M	Diamond	Hot Dip	Plain	34° Paper Tape, Strip
1½ x .148	M002264	2.M	Diamond	Hot Dip	Plain	34° Paper Tape, Strip
2½ x .148	M002266	1.5M	Diamond	Hot Dip	Plain	34° Paper Tape, Strip
2½ x .162	M002268	1.2M	Diamond	Hot Dip	Plain	34° Paper Tape, Strip

Heat Treated

1½ x .148	MD17AQBD	2.M	Diamond	Bright	Plain	34° Paper Tape, Strip
2½ x .148	MD25AHAD	2.M	Diamond	Bright	Plain	34° Paper Tape, Strip
1½ x .148	MD17AEAD	2.M	Diamond	Hot Dip	Plain	34° Paper Tape, Strip
2½ x .148	MD25AEAD	2.M	Diamond	Hot Dip	Plain	34° Paper Tape, Strip

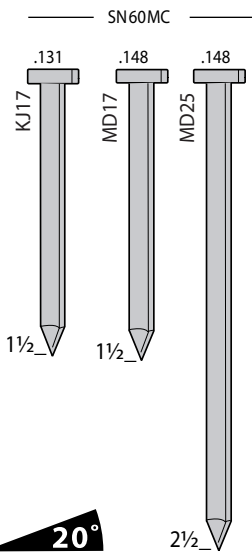

SENCO® 20° Metal Connector Paper Tape Collated Nails

Joist hangers, foundation anchors, seismic and hurricane straps and ties, standard tensile, non-hardened nails

Length	Item Code	Box Count	Point	Finish	Coating	Collation
1½ x .131	KJ17APAT	2.M	Diamond	Bright	Plain	20° Paper Tape, Strip
1½ x .148	MD17APAT	2.M	Diamond	Bright	Plain	20° Paper Tape, Strip
2½ x .148	MD25APBT	2.M	Diamond	Bright	Sencote	20° Paper Tape, Strip
1½ x .131	KJ17ASAT	2.M	Diamond	Hot Dip	Plain	20° Paper Tape, Strip
1½ x .148	MD17ASAT	2.M	Diamond	Hot Dip	Plain	20° Paper Tape, Strip
2½ x .148	MD25ASBT	2.M	Diamond	Hot Dip	Sencote	20° Paper Tape, Strip



Framing Nails 20° Full Round Head Smooth Shank

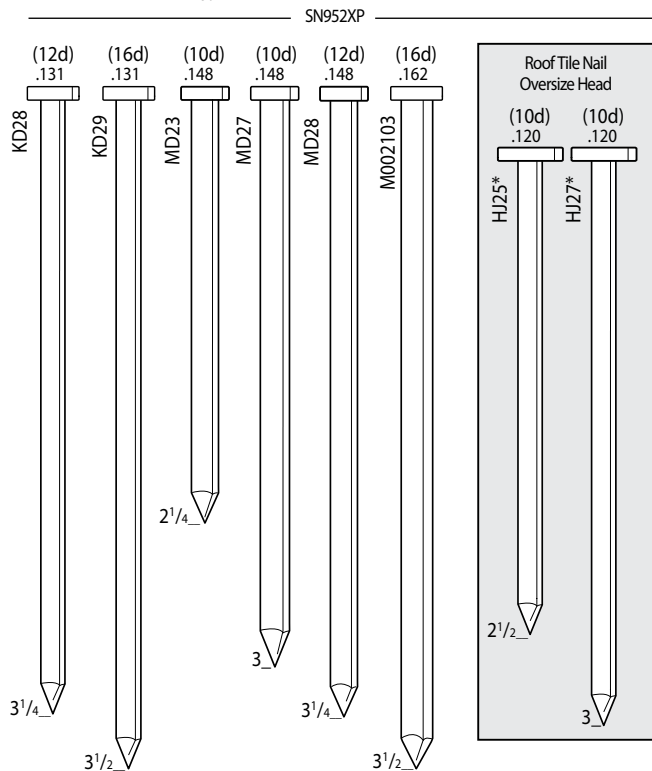
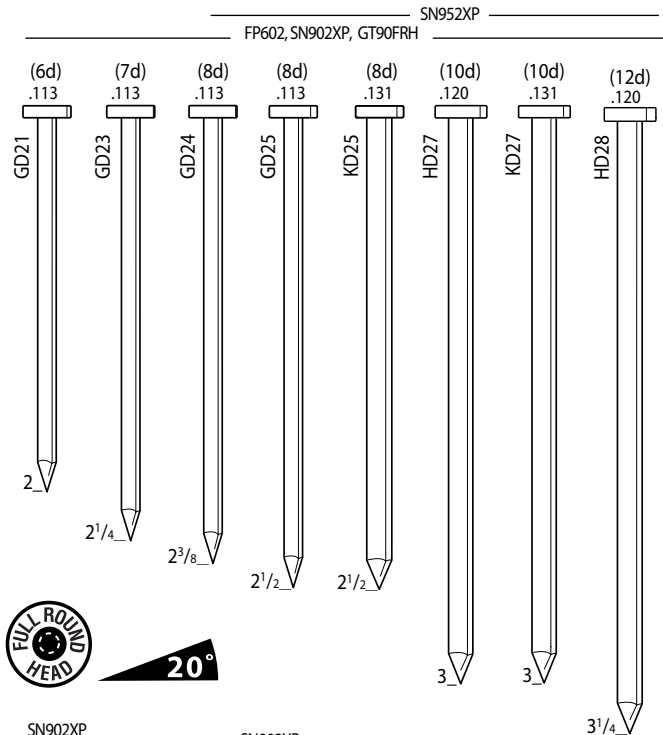

SENCO® 20° Smooth Shank Plastic Collated Nails

Framing, sheathing, subfloor, decks, trusses and pallets

Length	Item Code	Box Count	Point	Finish	Coating
2 x .113	GD21APBSN	5.M	Diamond	Bright	Sencote
2¼ x .113	GD23AHAS	2.8M	Diamond	Bt. Hardened	Plain
2¼ x .148	MD23APBSN	4.M	Diamond	Bright	Sencote
2⅝ x .113	M002063	2.5M	Diamond	Bright	Sencote
2⅞ x .113	GD24APBSN	5.M	Diamond	Bright	Sencote
2½ x .113	GD25APBSN	5.M	Diamond	Bright	Sencote
2½ x .131	KD25APBSN	4.M	Diamond	Bright	Sencote
2½ x .131	M002105	2.5M	Diamond	Bright	Sencote
3 x .120	HD27APBSN	4.M	Diamond	Bright	Sencote
3 x .131	KD27APBSN	4.M	Diamond	Bright	Sencote
3 x .131	M002044	2.5M	Diamond	Bright	Sencote
3 x .148	MD27APBSN	4.M	Diamond	Bright	Sencote
3 x .148	M002102	2.M	Diamond	Bright	Sencote
3¼ x .120	HD28APBSN	4.M	Diamond	Bright	Sencote
3¼ x .131	KD28APBSN	4.M	Diamond	Bright	Sencote
3¼ x .131	M002045	2.5M	Diamond	Bright	Sencote
3¼ x .148	MD28APBSN	4.M	Diamond	Bright	Sencote
3½ x .131	KD29APBSN	4.M	Diamond	Bright	Sencote
3½ x .131	M002101	2.5M	Diamond	Bright	Sencote
3½ x .162	M002103	1.8M	Diamond	Bright	Sencote
2 x .113	GD21AABS	5.M	Diamond	Galv	Sencote
2½ x .113	GD25AABS	5.M	Diamond	Galv	Sencote
2½ x .113	M002098	2.5M	Diamond	Galv	Sencote
2½ x .120	HJ25ADBS*	2.3M	Diamond	WeatherX™2	Sencote
2½ x .131	KD25AABS	2.5M	Diamond	Galv	Sencote
3 x .120	HJ27ADBS*	2.3M	Diamond	WeatherX™2	Sencote
3 x .131	KD27ASBS	2.5M	Diamond	Hot Dip	Sencote
3 x .131	KD27AABS	4.M	Diamond	Galv	Sencote
3 x .131	M002046	2.5M	Diamond	Galv	Sencote
3¼ x .131	KD28ASBS	2.5M	Diamond	Hot Dip	Sencote
3¼ x .131	KD28AABS	4.M	Diamond	Galv	Sencote
3¼ x .131	M002047	2.5M	Diamond	Galv	Sencote
3½ x .131	KD29ASBS	2.5M	Diamond	Hot Dip	Sencote
3½ x .131	KD29AABS	4.M	Diamond	Galv	Sencote
3½ x .131	M002106	2.5M	Diamond	Galv	Sencote
3¼ x .131	KD28AGBS	1.M	Diamond	Stainless	Sencote

* Roof tile nails, drive with the FramePro™752XP or SN952XP

Full Round Head Strip Nails

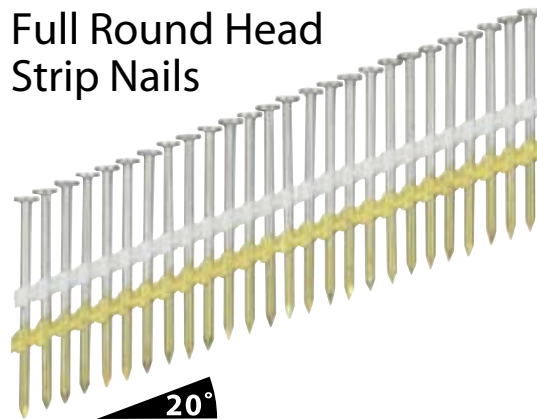

Framing Nails 20° Full Round Head Ring Shank

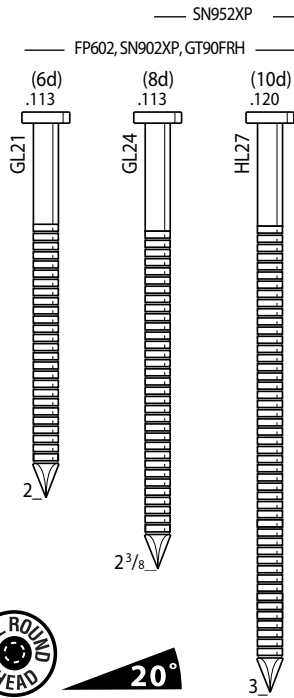

SENCO® 20° Ring Shank Plastic Collated Nails

Framing, sheathing, subfloor, decks, trusses, and pallets

Length	Item Code	Box Count	Point	Finish	Coating
2 x .113	GL21APBSN	5.M	Diamond	Bright	Sencote
2 3/8 x .113	GL24APBSN	5.M	Diamond	Bright	Sencote
2 3/8 x .113	M002041	2.5M	Diamond	Bright	Sencote
2 x .113	GL21ASBS	2.5M	Diamond	Hot Dip	Sencote
2 3/8 x .113	GL24AABSN	5.M	Diamond	Galv	Sencote
2 3/8 x .113	M002042	2.5M	Diamond	Galv	Sencote
2 3/8 x .113	GL24ASBS	2.5M	Diamond	Hot Dip	Sencote
3 x .120	HL27AABSN	4.M	Diamond	Galv	Sencote
3 x .120	HL27ASBS	2.5M	Diamond	Hot Dip	Sencote
2 3/8 x .113	GL24AGBS	1.M	Diamond	Stainless	Sencote
3 x .120	HL27AGBS	1.M	Diamond	Stainless	Sencote

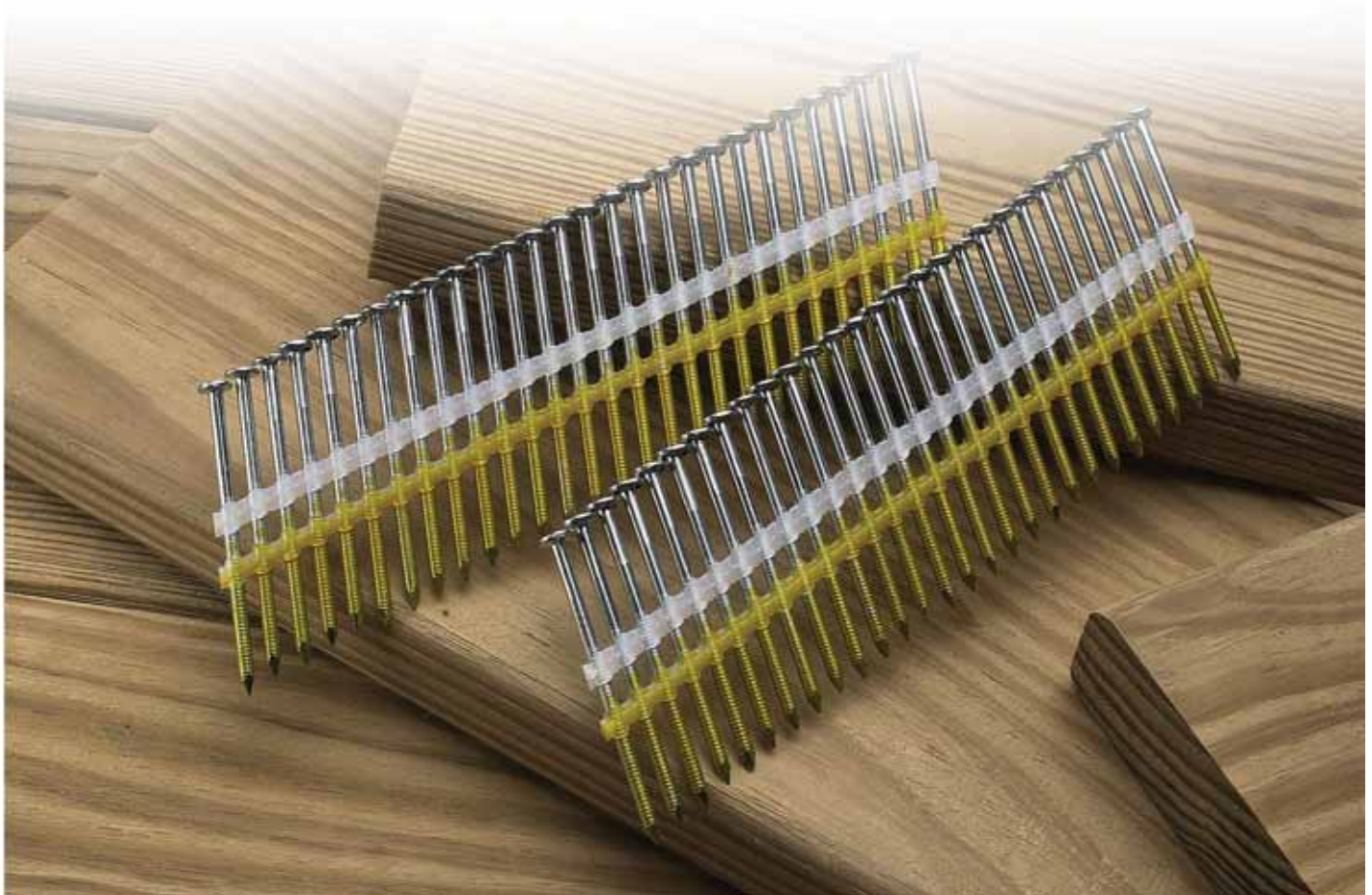

Framing Nails 15° Coil Framing Nails Smooth & Ring Shank

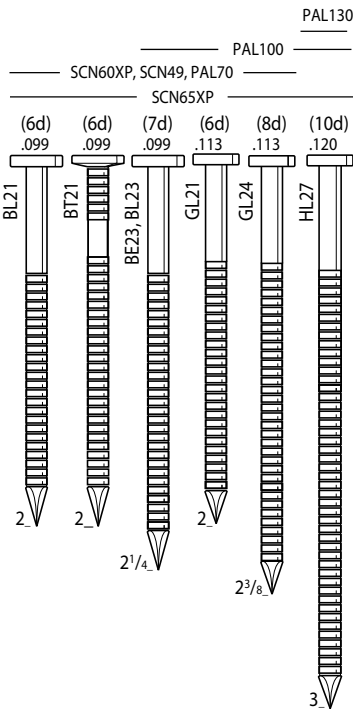
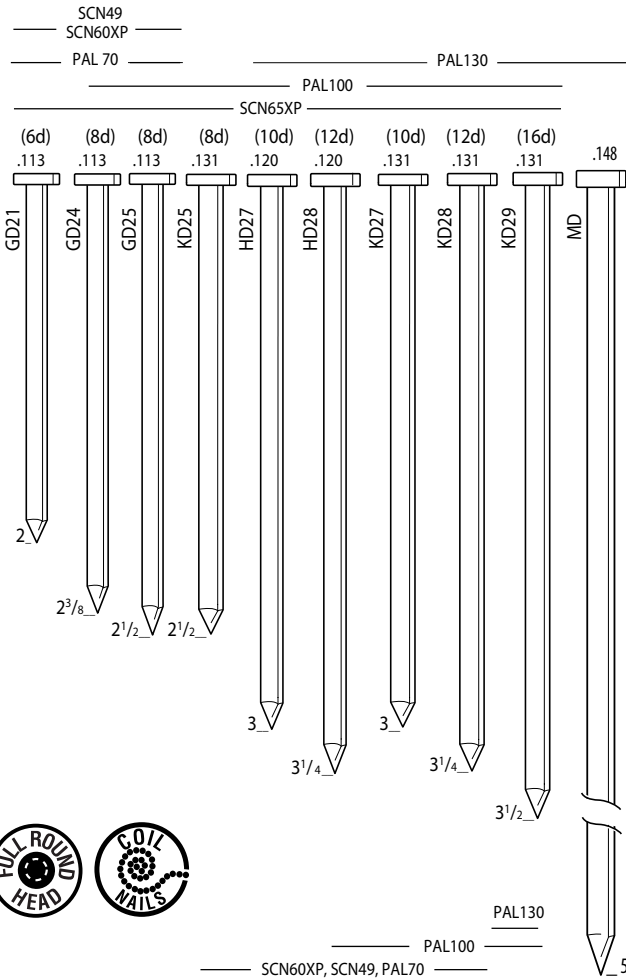

SENCO® Smooth Shank Framing Coil Nails

Framing, sheathing, pallets, subfloor, decks and trusses

Length	Item Code	Box Count	Point	Finish	Coating	Collation
2 x .113	GD21APBF	6.6M	Diamond	Bright	Sencote	Angular, flat wire wound
2 3/8 x .113	GD24APBF	6.6M	Diamond	Bright	Sencote	Angular, flat wire wound
2 3/8 x .113	M003005	2.7M	Diamond	Bright	Sencote	Angular, flat wire wound
2 1/2 x .113	GD25APBF	6.6M	Diamond	Bright	Sencote	Angular, flat wire wound
2 1/2 x .131	KD25APBF	3.6M	Diamond	Bright	Sencote	Angular, flat wire wound
2 1/2 x .131	M003014	2.4M	Diamond	Bright	Sencote	Angular, flat wire wound
3 x .120	HD27APBF	4.4M	Diamond	Bright	Sencote	Angular, flat wire wound
3 x .131	KD27APBF	3.6M	Diamond	Bright	Sencote	Angular, flat wire wound
3 x .131	M003007	2.4M	Diamond	Bright	Sencote	Angular, flat wire wound
3 1/4 x .120	HD28APBF	4.4M	Diamond	Bright	Sencote	Angular, flat wire wound
3 1/4 x .131	KD28APBF	3.6M	Diamond	Bright	Sencote	Angular, flat wire wound
3 1/4 x .131	M003009	2.4M	Diamond	Bright	Sencote	Angular, flat wire wound
3 1/2 x .131	KD29APBF	3.6M	Diamond	Bright	Sencote	Angular, flat wire wound
5 x .131	MD34APBF	3.6M	Diamond	Bright	Sencote	Angular, flat wire wound
2 x .113	GD21AABF	6.6M	Diamond	Galv	Sencote	Angular, flat wire wound
2 1/2 x .113	GD25AABF	6.6M	Diamond	Galv	Sencote	Angular, flat wire wound
3 x .131	KD27AABF	3.6M	Diamond	Galv	Sencote	Angular, flat wire wound
3 x .131	KD27ASBF	2.4M	Diamond	Hot Dip	Sencote	Angular, flat wire wound
3 1/4 x .131	KD28AABF	3.6M	Diamond	Galv	Sencote	Angular, flat wire wound
3 1/4 x .131	KD28ASBF	2.4M	Diamond	Hot Dip	Sencote	Angular, flat wire wound

SENCO® Ring Shank Framing Coil Nails

Framing, sheathing, pallets, subfloor, decks and trusses

Length	Item Code	Box Count	Point	Finish	Coating	Collation
2 x .099	BL21APBF	6.6M	Diamond	Bright	Sencote	Angular, flat wire wound
2 x .099	BT21APBF	6.6M	Diamond	Bright	Sencote	Angular, flat wire wound
2 x .113	GL21APBF	6.6M	Diamond	Bright	Sencote	Angular, flat wire wound
2 1/4 x .099	BL23APBF	6.6M	Diamond	Bright	Sencote	Angular, flat wire wound
2 3/8 x .113	GL24APBF	6.6M	Diamond	Bright	Sencote	Angular, flat wire wound
2 1/4 x .099	BE23AABF	6.6M	Diamond	Galv	Sencote	Angular, flat wire wound
2 3/8 x .113	GL24AABF	6.6M	Diamond	Galv	Sencote	Angular, flat wire wound
2 3/8 x .113	GL24ASBF	2.7M	Diamond	Hot Dip	Sencote	Angular, flat wire wound
3 x .120	HL27AABF	3.6M	Diamond	Galv	Sencote	Angular, flat wire wound
3 x .120	HL27ASBF	2.4M	Diamond	Hot Dip	Sencote	Angular, flat wire wound
2 3/8 x .113	GL24AGBF	2.7M	Diamond	Stainless	Sencote	Angular, flat wire wound
3 x .120	HL27AGBF	2.4M	Diamond	Stainless	Sencote	Angular, flat wire wound

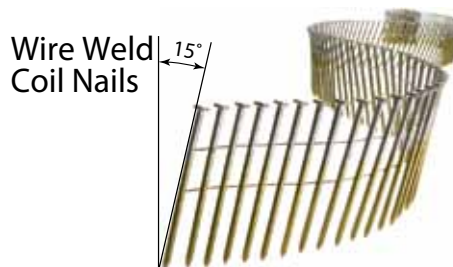

Coil Framing Nails 15° Screw, Duplex Shanks & Wood to Masonry Smooth Shank

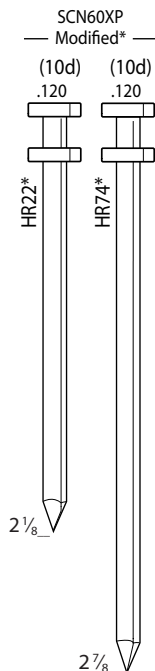
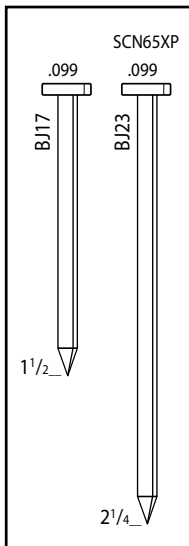
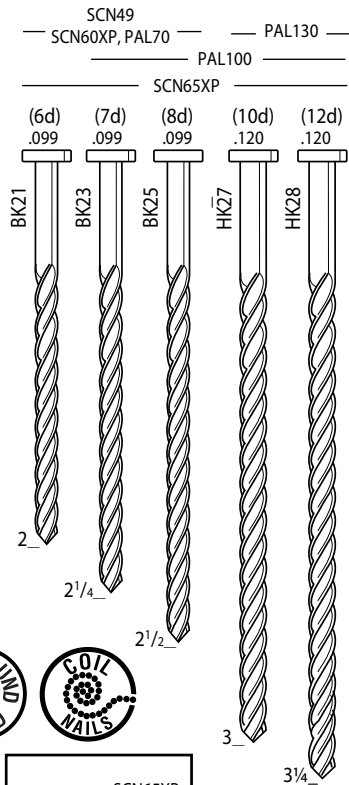

SENCO® Screw Shank Framing Coil Nails

Framing, sheathing, pallets, subfloor, decks and trusses

Length	Item Code	Box Count	Point	Finish	Coating	Collation
2 x .099	BK21BPBFN	9.M	Blunt Dia.	Bright	Sencote	Angular, flat wire wound
2 x .099	BK21EPBF	6.6M	Chisel	Bright	Sencote	Angular, flat wire wound
2¼ x .099	BK23BPBFN	9.M	Blunt Dia.	Bright	Sencote	Angular, flat wire wound
2¼ x .099	BK23EPBF	6.6M	Chisel	Bright	Sencote	Angular, flat wire wound
2½ x .099	BK25BPBFN	6.M	Blunt Dia.	Bright	Sencote	Angular, flat wire wound
3 x .120	HK27APBFN	4.M	Diamond	Bright	Sencote	Angular, flat wire wound
3¼ x .120	HK28ASBF	2.4M	Diamond	Hot Dip	Sencote	Angular, flat wire wound

SENCO® Smooth Shank Stiff Stock Coil Nails

Wood to masonry

Length	Item Code	Box Count	Point	Finish	Coating	Collation
1½ x .099	BJ17AQBFN	3.3M	Diamond	Bright	Sencote	Angular, flat wire wound
1½ x .099	M003011	3.M	Diamond	Bright	Sencote	Angular, flat wire wound
2¼ x .099	BJ23AQBFN	3.3M	Diamond	Bright	Sencote	Angular, flat wire wound
2¼ x .099	M003012	3.M	Diamond	Bright	Sencote	Angular, flat wire wound

SENCO® Duplex Smooth Shank Coil Nails

Framing, trusses, crating and concrete forms

Length	Item Code	Box Count	Point	Finish	Coating	Collation
2⅞ x .120	HR22APAF	5.4M	Diamond	Bright	Plain	Angular, flat wire wound
2⅞ x .120	HR74APAF	3.6M	Diamond	Bright	Plain	Angular, flat wire wound

*Requires a special order modified SCN60XP Tool (order XA1739)

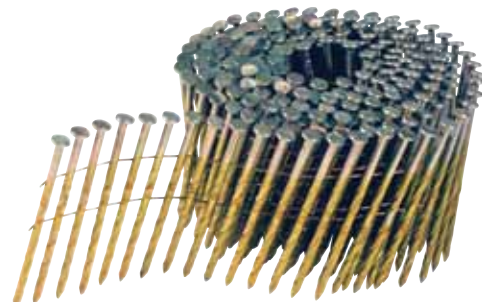

Coil Packaging, Siding & Drywall Nails 15° Smooth & Ring Shank

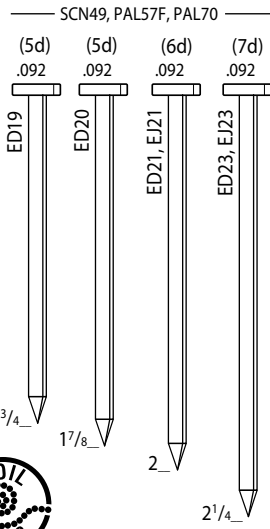

SENCO® Smooth Shank-Packaging Coil Nails

Packaging, siding, fencing, pallets and underlayment

Length	Item Code	Box Count	Point	Finish	Coating	Collation
1 1/8 x .092	ED20APBH	7.2M	Diamond	Bright	Sencote	Angular, flat wire wound
1 3/4 x .092	ED19ASBC	3.6M	Diamond	Hot Dip	Sencote	Angular plastic carrier strip wound
2 x .092	ED21AABH	3.6M	Diamond	Galv	Sencote	Angular, flat wire wound
2 x .092	ED21ADBH	3.6M	Diamond	WeatherX™2	Sencote	Angular, flat wire wound
2 x .092	EJ21ADBC	6.4M	Diamond	WeatherX™2	Sencote	Angular plastic carrier strip wound
2 x .092	EJ21ADBH	7.2M	Diamond	WeatherX™2	Sencote	Angular, flat wire wound
2 1/4 x .092	ED23AABH	3.6M	Diamond	Galv	Sencote	Angular, flat wire wound
2 1/4 x .092	ED23ADBH	3.6M	Diamond	WeatherX™2	Sencote	Angular, flat wire wound
2 1/4 x .092	ED23ASBC	3.6M	Diamond	Hot Dip	Sencote	Angular plastic carrier strip wound
2 1/4 x .092	EJ23ADBH	7.2M	Diamond	WeatherX™2	Sencote	Angular, conical wire wound
2 1/4 x .092	EJ23ASBC	3.6M	Diamond	Hot Dip	Sencote	Angular plastic carrier strip wound

SENCO® Ring Shank-Packaging and Siding Coil Nails

Packaging, siding, fencing, wood shingles, crating and pallets

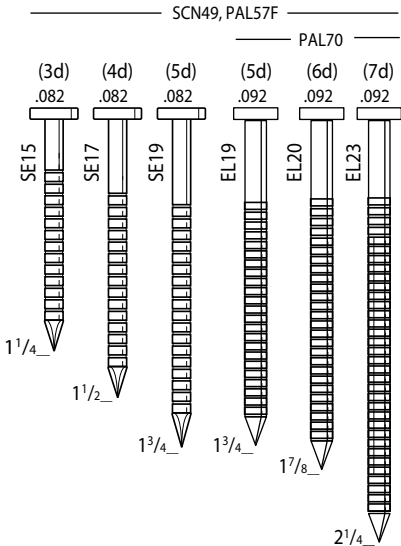

Length	Item Code	Box Count	Point	Finish	Coating	Collation
1 1/4 x .082	SE15APB	15.M	Diamond	Bright	Sencote	Angular, conical wire wound
1 1/4 x .082	SE15APBH	15.M	Diamond	Bright	Sencote	Angular, flat wire wound
1 1/2 x .082	SE17APB	12.M	Diamond	Bright	Sencote	Angular, conical wire wound
1 1/2 x .082	SE17APBH	12.M	Diamond	Bright	Sencote	Angular, flat wire wound
1 3/4 x .082	SE19APB	12.M	Diamond	Bright	Sencote	Angular, conical wire wound
1 3/4 x .082	SE19APBH	12.M	Diamond	Bright	Sencote	Angular, flat wire wound
1 3/4 x .092	EL19ASBC	3.6M	Diamond	Hot Dip	Sencote	Angular plastic carrier strip wound
1 3/4 x .092	EL19ASBH	3.6M	Diamond	Hot Dip	Sencote	Angular, flat wire wound
1 7/8 x .092	EL20AABH	3.6M	Diamond	Galv	Sencote	Angular, flat wire wound
1 7/8 x .092	EL20ASBH	3.6M	Diamond	Hot Dip	Sencote	Angular, flat wire wound
2 x .092	EL21ASBH	3.6M	Diamond	Hot Dip	Sencote	Angular, flat wire wound
2 1/4 x .092	EL23AABH	3.6M	Diamond	Galv	Sencote	Angular, flat wire wound
2 1/4 x .092	EL23ASBC	3.6M	Diamond	Hot Dip	Sencote	Angular plastic carrier strip wound
2 1/4 x .092	EL23ASBH	3.6M	Diamond	Hot Dip	Sencote	Angular, flat wire wound
1 3/4 x .092	EL19AGBH	3.6M	Diamond	Stainless	Sencote	Angular, flat wire wound
1 7/8 x .092	EL20AGBH	3.6M	Diamond	Stainless	Sencote	Angular, flat wire wound
2 x .092	EL21AGBH	3.6M	Diamond	Stainless	Sencote	Angular, flat wire wound
2 1/4 x .092	EL23AGBH	3.6M	Diamond	Stainless	Sencote	Angular, flat wire wound

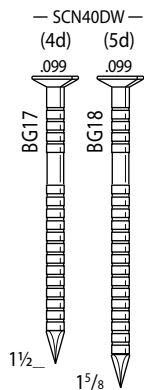

SENCO® Drywall Ring Shank Bugle Head Coil Nails

Length	Item Code	Box Count	Point	Finish	Coating	Collation
1 1/2 x .099	BG17AAA	9.6M	Diamond	Galv	Plain	Angular, conical wire wound
1 1/2 x .099	BG17AAAQ	6.4M	Diamond	Galv	Plain	Angular, conical wire wound
1 5/8 x .099	BG18AAA	9.6M	Diamond	Galv	Plain	Angular, conical wire wound
1 5/8 x .099	BG18AAAQ	6.4M	Diamond	Galv	Plain	Angular, conical wire wound



Coil Roofing Nails Ring & Smooth Shank

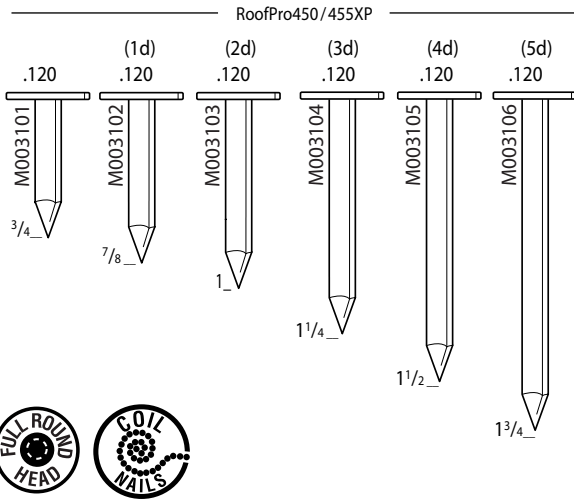

SENCO® Smooth Shank Roofing Coil Nails

Asphalt & fiberglass shingles, siding and vapor barriers

Length	Item Code	Box Count	Point	Finish	Coating	Collation
3/4 x .120	M003101	7.2M	Diamond	Galv	Plain	Angular, flat wire wound
7/8 x .120	M003102	7.2M	Diamond	Galv	Plain	Angular, flat wire wound
1 x .120	M003103	7.2M	Diamond	Galv	Plain	Angular, flat wire wound
1 1/4 x .120	M003104	7.2M	Diamond	Galv.	Plain	Angular, flat wire wound
1 1/2 x .120	M003105	7.2M	Diamond	Galv	Plain	Angular, flat wire wound
1 3/4 x .120	M003106	7.2M	Diamond	Galv	Plain	Angular, flat wire wound

SENCO has a complete line of tools, fasteners, and compressors for all you roofing applications.

- **Asphalt and fiberglass Roofing coil nailers**
RoofPro®455XP, RoofPro®450
- **Roofing stapler**
WC150XP,
- **Cedar shakes**
SCN49 coil nailer,
SNS Series of staplers
- **Clay roof tiles**
SN952XP 20° Nailer
- **House wrap and roofing felt**
BC58 Button Cap Stapler
A11 Stapling Hammer

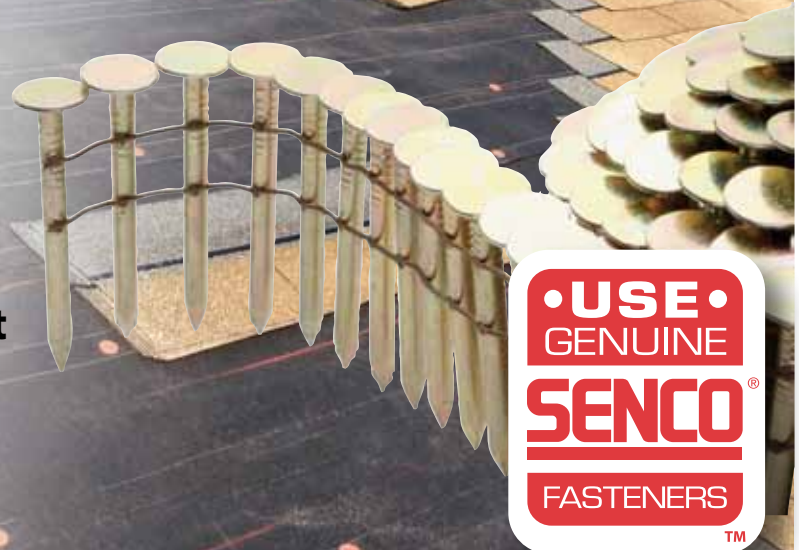

FASTENERS

Fine Wire Staples 22 - 20 Gauge

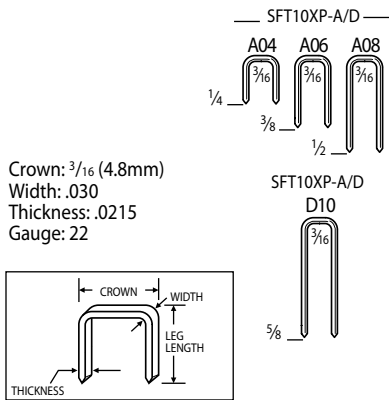

SENCO® 22 Ga. 3/16" Crown Fine Wire

Furniture upholstery, felt, insulation, casebacks, screening and shoes

Length	Item Code	Box Count	Point	Finish	Coating
1/4	A04BAAN	10.M	Chisel	Galv	Sencote
3/8	A06BABN	30.M	Chisel	Galv	Sencote
3/8	A06BABP	40.M	Chisel	Galv	Sencote
1/2	A08BAB	20.M	Chisel	Galv	Sencote
1/2	A08BABP	30.M	Chisel	Galv	Sencote
5/8	D10BAB	20.M	Chisel	Galv	Sencote
5/8	D10BABN	20.M	Chisel	Galv	Sencote
5/8	D10BABPN	23.M	Chisel	Galv	Sencote

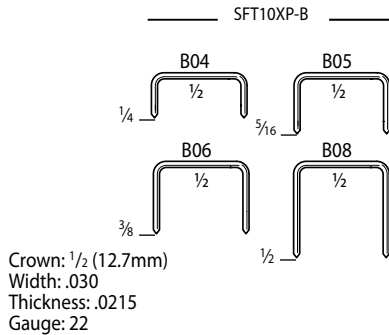

SENCO® 22 Ga. 1/2" Crown Fine Wire

Furniture upholstery, felt, insulation, casebacks, screening and shoes

Length	Item Code	Box Count	Point	Finish	Coating
1/4	B04BAAPN	25.M	Chisel	Galv	Plain
5/16	B05BAAP	45.M	Chisel	Galv	Plain
5/16	B05DAA	45.M	Outside Chisel	Galv	Plain
3/8	B06BAAP	40.M	Chisel	Galv	Plain
1/2	B08BAAP	25.M	Chisel	Galv	Plain

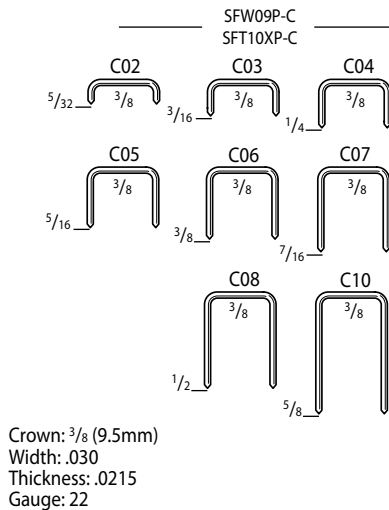

SENCO® 22 Ga. 3/8" Crown Fine Wire

Furniture upholstery, felt, insulation, casebacks, screening and shoes

Length	Item Code	Box Count	Point	Finish	Coating
5/32	C02BAAPN	60.M	Chisel	Galv	Plain
3/16	C03BAAPN	55.M	Chisel	Galv	Plain
1/4	C04BAAP	35.M	Chisel	Galv	Plain
1/4	C04DAAP	35.M	Outside Chisel	Galv	Plain
5/16	C05BAAPN	28.M	Chisel	Galv	Plain
3/8	C06BAAP	50.M	Chisel	Galv	Plain
7/16	C07BAAPN	40.M	Chisel	Galv	Plain
1/2	C08BAAP	35.M	Chisel	Galv	Plain
5/8	C10BAAP	27.M	Chisel	Galv	Plain
3/16	C03BGAN	25.M	Chisel	Stainless	Plain
1/4	C04BGA	35.M	Chisel	Stainless	Plain
3/8	C06BHA	10.M	Chisel	Stainless	Plain
3/8	C06BGA	10.M	Chisel	Stainless	Plain

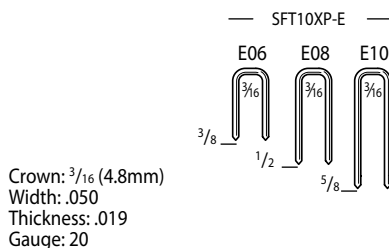

SENCO® 20 Ga. 3/16" Crown Fine Wire

Furniture upholstery, felt, insulation, casebacks, screening and shoes

Length	Item Code	Box Count	Point	Finish	Coating
3/8	E06BAA	10.M	Chisel	Galv	Plain
1/2	E08BAA	10.M	Chisel	Galv	Plain
5/8	E10BAA	5.M	Chisel	Galv	Plain

Fine Wire Staples 21 - 18 Gauge

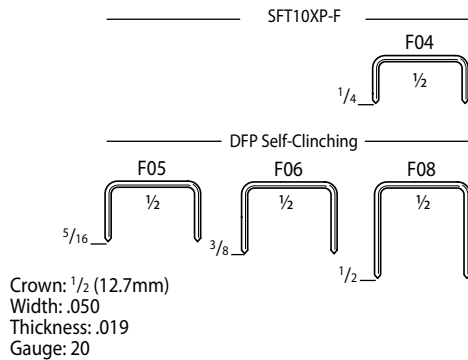

SENCO® 20 Ga. 1/2" Crown Fine Wire

Upholstery, felt, insulation and casebacks,
D Tool: Bedding, packaging and set-up boxes

Length	Item Code	Box Count	Point	Finish	Coating
1/4	F04BAAN	10.M	Chisel	Galv	Plain
1/4	F04BAAP	17.M	Chisel	Galv	Plain
3/16	F05BAAP	24.M	Chisel	Galv	Plain
3/8	F06BAA	10.M	Chisel	Galv	Plain
3/8	F06BAAP	24.M	Chisel	Galv	Plain
1/2	F08BAAN	10.M	Chisel	Galv	Plain
1/2	F08BAAP	10.M	Chisel	Galv	Plain
3/8	F06BGA	10.M	Chisel	Stainless	Plain
1/2	F08BGA	10.M	Chisel	Stainless	Plain

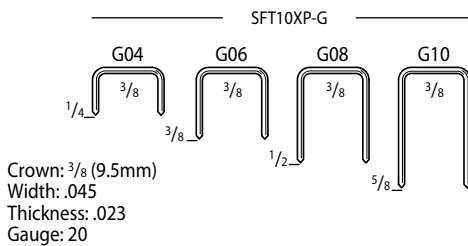

SENCO® 20 Ga. 3/8" Crown Fine Wire

Upholstery, felt, insulation and casebacks

Length	Item Code	Box Count	Point	Finish	Coating
1/4	G04BAAN	10.M	Chisel	Galv	Plain
3/8	G06BABN	5.M	Chisel	Galv	Plain
1/2	G08BAB	5.M	Chisel	Galv	Plain
5/8	G10BAB	5.M	Chisel	Galv	Plain
3/8	G06BHA	5.M	Divergent	Stainless	Plain

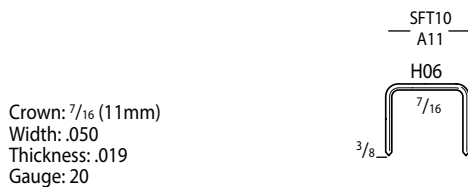

SENCO® 20 Ga. 7/16" Crown Fine Wire

Insulation, vapor barriers & roofing felt

Length	Item Code	Box Count	Point	Finish	Coating
3/8	H06BAA	5.M	Chisel	Galv	Plain

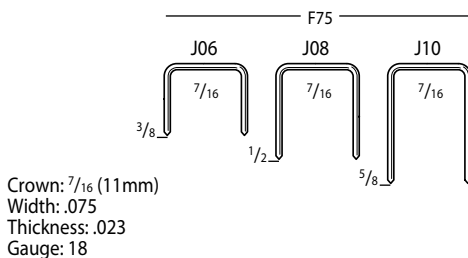

SENCO® 18 Ga. 7/16" Crown Fine Wire

Packaging, joining materials to corrugated

Length	Item Code	Box Count	Point	Finish	Coating
3/8	J06BAA	5.M	Chisel	Galv	Plain
1/2	J08BAAN	5.M	Chisel	Galv	Plain
5/8	J10BAAN	5.M	Chisel	Galv	Plain

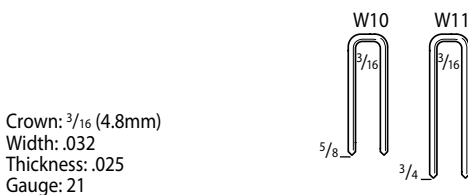

SENCO® 21 Ga. 3/16" Crown Fine Wire

Cabinets, casebacks, soffits, molding & lattice

Length	Item Code	Box Count	Point	Finish	Coating
5/8	W10BAB	10.M	Chisel	Galv	Sencote
3/4	W11BABN	10.M	Chisel	Galv	Sencote

FASTENERS

Medium Wire Staples 19 - 18 Gauge

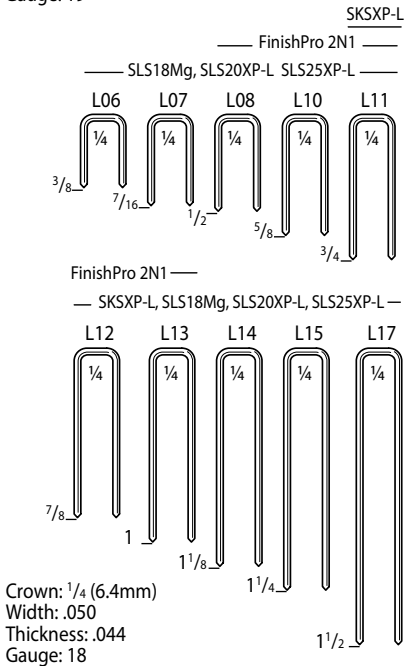
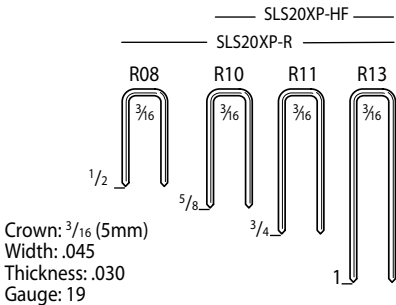
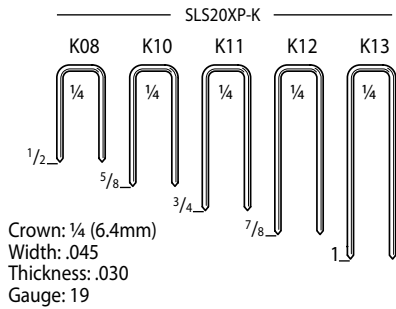

SENCO® 19 Ga. 1/4" Crown Medium Wire

Cabinets, drawers, soffits, lattice, casebacks

Length	Item Code	Box Count	Point	Finish	Coating
1/2	K08BABN	10.M	Chisel	Galv	Sencote
5/8	K10BABN	10.M	Chisel	Galv	Sencote
3/4	K11BAB	10.M	Chisel	Galv	Sencote
7/8	K12BAB	5.M	Chisel	Galv	Sencote
1	K13BABN	5.M	Chisel	Galv	Sencote

SENCO® 19 Ga. 3/16" Crown Medium Wire

Hardwood flooring, cabinets, drawers, lattice

Length	Item Code	Box Count	Point	Finish	Coating
1/2	R08BAB	5.M	Blunt	Galv	Sencote
5/8	R10BAB	5.M	Blunt	Galv	Sencote
3/4	R11BAB	5.M	Blunt	Galv	Sencote
1	R13BAB	5.M	Blunt	Galv	Sencote

SENCO® 18 Ga. 1/4" Crown Medium Wire

Cabinets, casebacks, drawers, upholstery, soffits, underlayment, lattice & insulative sheathing

Length	Item Code	Box Count	Point	Finish	Coating	Package
3/4	L11BRB	5.M	Chisel	Bright	Sencote	Box
1	L13BRBN	5.M	Chisel	Bright	Sencote	Box
1	L13BRBP	5.M	Chisel	Bright	Sencote	Box
1 1/8	L14BRB	5.M	Chisel	Bright	Sencote	Box
1 1/4	L15BRB	5.M	Chisel	Bright	Sencote	Box
3/8	L06BAB	10.M	Chisel	Galv	Sencote	Box
7/16	L07BABP	24.M	Chisel	Galv	Sencote	Box
7/16	L07BQBP	24.M	Chisel	Class1 Galv	Sencote	Box
1/2	L08BAB	10.M	Chisel	Galv	Sencote	Box
5/8	L10BABN	5.M	Chisel	Galv	Sencote	Box
5/8	L10HABN	5.M	Cross Cut	Chisel Galv	Sencote	Box
3/4	L11BAB	5.M	Chisel	Galv	Sencote	Box
3/4	L11HAB	5.M	Cross Cut	Chisel Galv	Sencote	Box
7/8	L12BAB	5.M	Chisel	Galv	Sencote	Box
7/8	L12BQB	5.M	Chisel	Class1 Galv	Sencote	Box
7/8	L12LAA	5.M	Divergent	Galv	Sencote	Box
1	L13BABN	5.M	Chisel	Galv	Sencote	Box
1	L13HABN	5.M	Cross Cut	Chisel Galv	Sencote	Box
1 1/8	L14BAB	5.M	Chisel	Galv	Sencote	Box
1 1/4	L15BAB	5.M	Chisel	Galv	Sencote	Box
1 1/2	L17BAB	5.M	Chisel	Galv	Sencote	Box
5/8	A800629	1.2M	Chisel	Galv	Sencote	Clamshell
3/4	A800759	.9M	Chisel	Galv	Sencote	Clamshell
1	A801009	.9M	Chisel	Galv	Sencote	Clamshell
1 1/4	A801259	.7M	Chisel	Galv	Sencote	Clamshell
1 1/2	A801509	.6M	Chisel	Galv	Sencote	Clamshell
Variety	A809909	.9M	Chisel	Galv	Sencote	Clamshell
3/4	L11BGA	5.M	Chisel	Stainless	Plain	Box
1 1/8	L14BGA	5.M	Chisel	Stainless	Plain	Box

Medium Wire Staples 18 Gauge

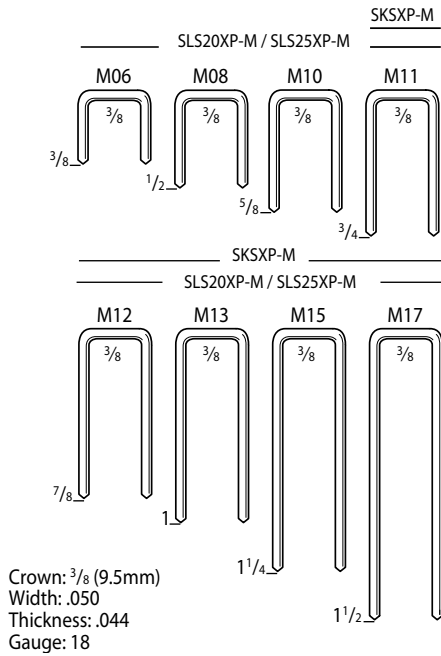

SENCO® 18 Ga. 3/8" Crown Medium Wire

Cabinets, casebacks, drawers, upholstery, soffits, underlayment, lattice and sheathing

Length	Item Code	Box Count	Point	Finish	Coating
$\frac{5}{8}$	M10BRBN	5.M	Chisel	Bright	Sencote
$\frac{3}{4}$	M11BRBN	5.M	Chisel	Bright	Sencote
1	M13BRB	5.M	Chisel	Bright	Sencote
$\frac{3}{8}$	M06BABN	10.M	Chisel	Galv	Sencote
$\frac{1}{2}$	M08BAB	10.M	Chisel	Galv	Sencote
$\frac{5}{8}$	M10BABN	5.M	Chisel	Galv	Sencote
$\frac{3}{4}$	M11BABN	5.M	Chisel	Galv	Sencote
$\frac{7}{8}$	M12BAB	5.M	Chisel	Galv	Sencote
1	M13BAB	5.M	Chisel	Galv	Sencote
$1\frac{1}{4}$	M15BAB	10.M	Chisel	Galv	Sencote
$1\frac{1}{2}$	M17BAB	10.M	Chisel	Galv	Sencote

Heavy Wire Staples 17 Gauge

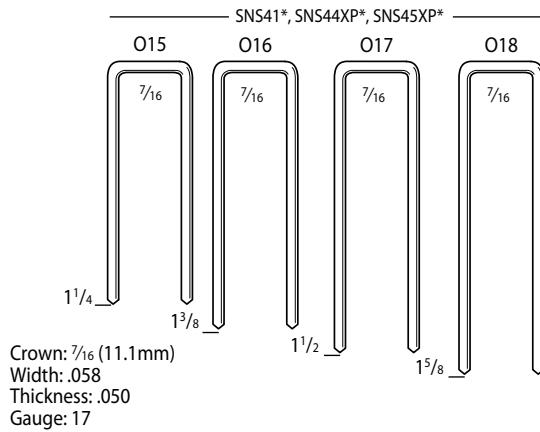

SENCO® 17 Ga. 7/16" Crown Heavy Wire

Furniture frames and crates.

Length	Item Code	Box Count	Point	Finish	Coating	Collation
$1\frac{1}{4}$	O15BRBB	10.M	Chisel	Bright	Sencote	Glued
$1\frac{3}{8}$	O16BRBB	10.M	Chisel	Bright	Sencote	Glued
$1\frac{1}{2}$	O17BRBB	10.M	Chisel	Bright	Sencote	Glued
$1\frac{5}{8}$	O18BRBB	10.M	Chisel	Bright	Sencote	Glued

* Drives only from SNS44XP and SNS45XP staplers manufactured after 05/2010, and SNS41 manufactured after 09/2010.
 For older tools, order upgrade kits: SNS41-YK0794, SNS44-YK0793, SNS45-FA0186



FASTENERS

Heavy Wire Staples 16 Gauge

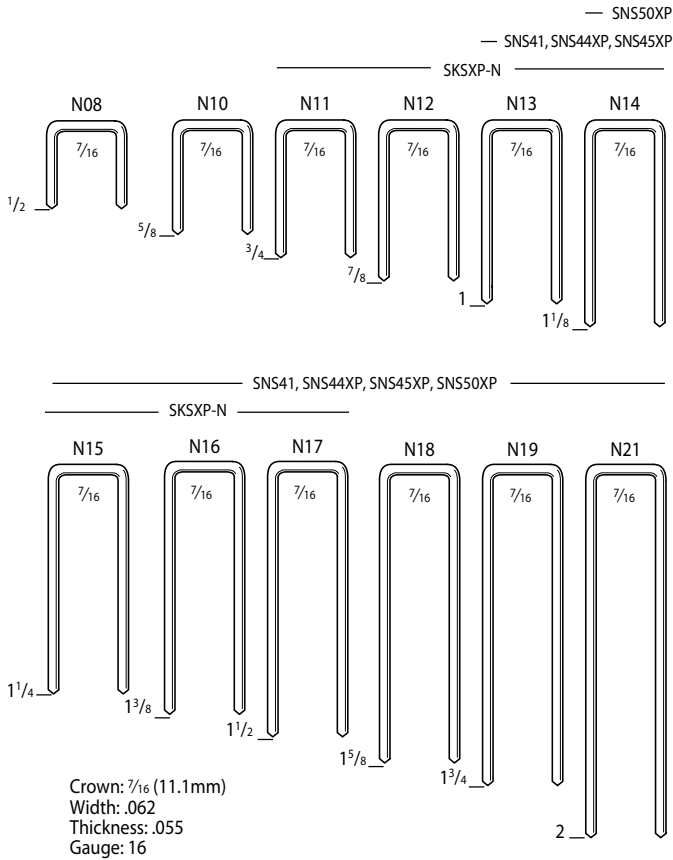

Note: Model numbers specify which tool or tools drive designated fasteners.

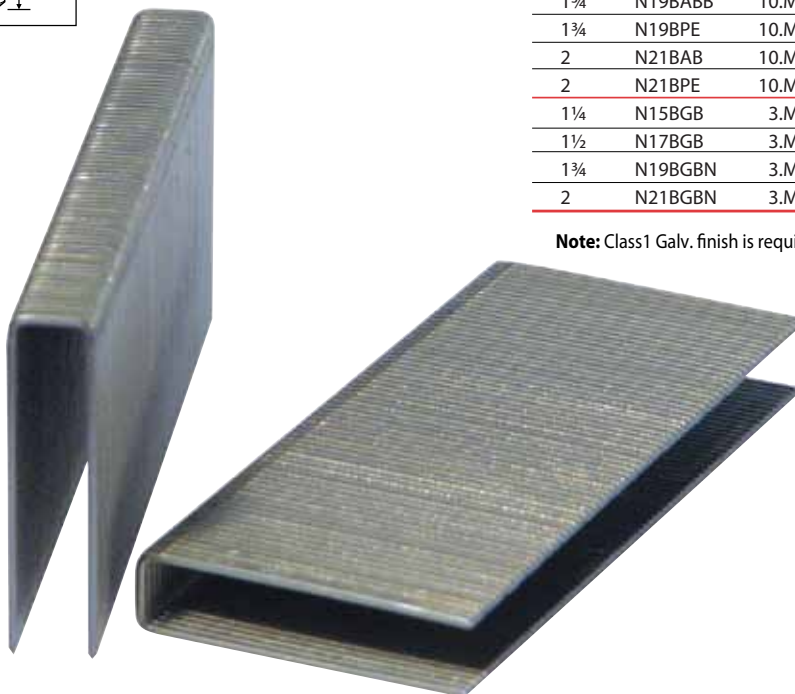
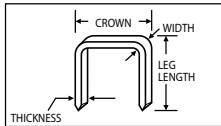

SENCO® 16 Ga. 7/16" Crown Heavy Wire

Cabinets, casebacks, drawers, upholstery, soffits, underlayment, lattice and sheathing

Length	Item Code	Box Count	Point	Finish	Coating	Collation
3/4	N11BRB	5.M	Chisel	Bright	Sencote	Tape
1	N13BRB	5.M	Chisel	Bright	Sencote	Tape
1 1/8	N14BRB	10.M	Chisel	Bright	Sencote	Tape
1 1/4	N15BRB	10.M	Chisel	Bright	Sencote	Tape
1 3/8	N16BRB	10.M	Chisel	Bright	Sencote	Tape
1 3/8	N16RRB	10.M	Step	Bright	Sencote	Tape
1 3/8	N16BRBG	10.M	Chisel	Bright	Sencote	Glued
1 1/2	N17BRB	10.M	Chisel	Bright	Sencote	Tape
1 1/2	N17BRBG	10.M	Chisel	Bright	Sencote	Glued
1 5/8	N18BRB	10.M	Chisel	Bright	Sencote	Tape
1 3/4	N19BRB	10.M	Chisel	Bright	Sencote	Tape
2	N21BRB	10.M	Chisel	Bright	Sencote	Tape
1/2	N08BABN	5.M	Chisel	Class1 Galv	Sencote	Tape
1/2	N08BBBN	5.M	Chisel	Reg. Galv	Sencote	Tape
1/2	N08FBB	5.M	Divergent	Reg. Galv	Sencote	Tape
5/8	N10BAB	5.M	Chisel	Class1 Galv	Sencote	Tape
3/4	N11BAB	5.M	Chisel	Class1 Galv	Sencote	Tape
7/8	N12BABN	5.M	Chisel	Class1 Galv	Sencote	Tape
7/8	N12FABN	5.M	Divergent	Class1 Galv	Sencote	Tape
1	N13BAB	5.M	Chisel	Class1 Galv	Sencote	Tape
1 1/8	N14BAB	10.M	Chisel	Class1 Galv	Sencote	Tape
1 1/8	N14FAB	10.M	Divergent	Class1 Galv	Sencote	Tape
1 1/4	N15BAB	10.M	Chisel	Class1 Galv	Sencote	Tape
1 1/4	N15FAB	10.M	Divergent	Class1 Galv	Sencote	Tape
1 3/8	N16BAB	10.M	Chisel	Class1 Galv	Sencote	Tape
1 1/2	N17BAB	10.M	Chisel	Class1 Galv	Sencote	Tape
1 1/2	N17BABB	10.M	Chisel	Class1 Galv	Sencote	Tape
1 1/2	N17BPE	10.M	Chisel	Reg. Galv	Sencote	Tape
1 5/8	N18BAB	10.M	Chisel	Class1 Galv	Sencote	Tape
1 3/4	N19BAB	10.M	Chisel	Class1 Galv	Sencote	Tape
1 3/4	N19BABB	10.M	Chisel	Class1 Galv	Sencote	Tape
1 3/4	N19BPE	10.M	Chisel	Reg. Galv	Sencote	Tape
2	N21BAB	10.M	Chisel	Class1 Galv	Sencote	Tape
2	N21BPE	10.M	Chisel	Reg. Galv	Sencote	Tape
1 1/4	N15BGB	3.M	Chisel	Stainless	Sencote	Tape
1 1/2	N17BGB	3.M	Chisel	Stainless	Sencote	Tape
1 3/4	N19BGBN	3.M	Chisel	Stainless	Sencote	Tape
2	N21BGBN	3.M	Chisel	Stainless	Sencote	Tape

Note: Class1 Galv. finish is required to meet most building code requirements.

Heavy Wire Staples 16 - 15 Gauge

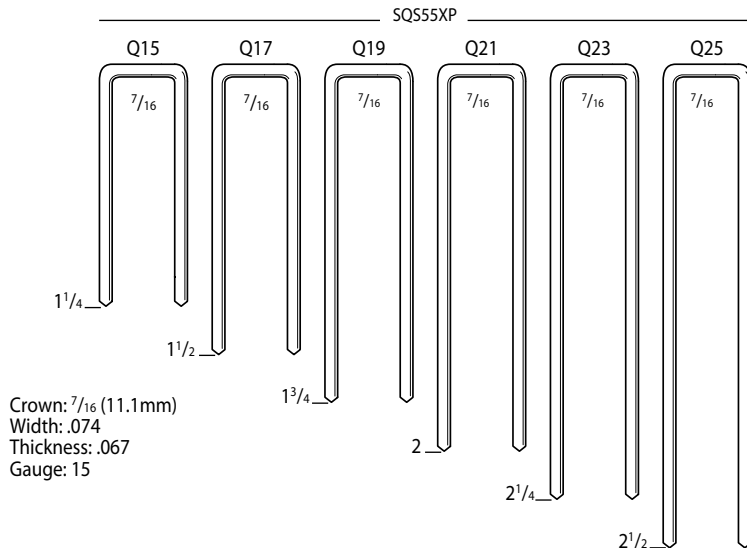
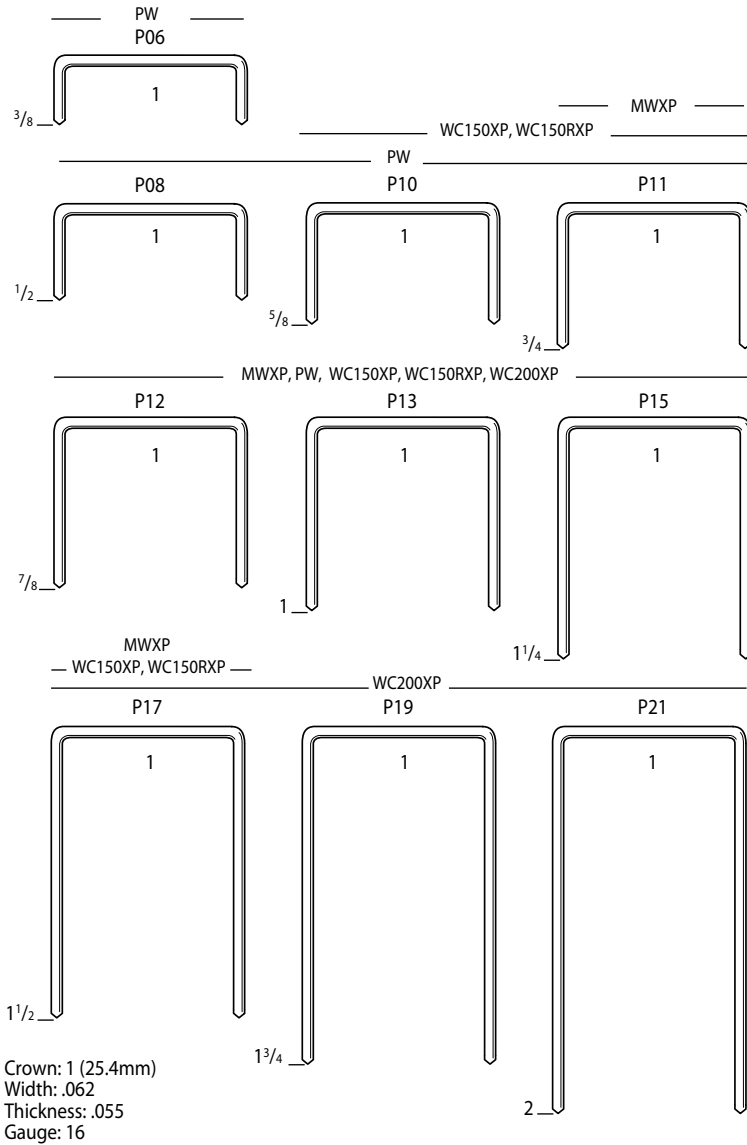

SENCO® 16 Ga. 1" Crown Heavy Wire

Sheathing, house wrap, composite roofing, roofing felt, corrugated containers, foam insulation board, furniture/cabinet frames and butt-joints

Length	Item Code	Box Count	Point	Finish	Coating
3/8	P06BAA	10.M	Chisel	Class1 Galv	Plain
1/2	P08BABT	10.M	Chisel	Class1 Galv	Sencote
5/8	P10BAB	10.M	Chisel	Class1 Galv	Sencote
5/8	P10FAB	10.M	Divergent	Class1 Galv	Sencote
5/8	P10BPE	10.M	Chisel	Reg. Galv	Coated
3/4	P11BAB	10.M	Chisel	Class1 Galv	Sencote
3/4	P11BPE	10.M	Chisel	Reg. Galv	Coated
7/8	P12BAB	10.M	Chisel	Class1 Galv	Sencote
1	P13BAB	10.M	Chisel	Class1 Galv	Sencote
1	P13BPE	10.M	Chisel	Reg. Galv	Sencote
1 1/4	P15BAB	10.M	Chisel	Class1 Galv	Sencote
1 1/4	P15BRE	10.M	Chisel	Reg. Galv	Sencote
1 1/2	P17BAB	10.M	Chisel	Class1 Galv	Sencote
1 3/4	P19BAB	5.M	Chisel	Class1 Galv	Sencote
2	P21BAB	5.M	Chisel	Class1 Galv	Sencote
1	P13BGBN	5.M	Outside Chisel	Stainless	Sencote

Note: Class1 Galv. finish is required to meet most building code requirements.

SENCO® 15 Ga. 7/16" Crown Heavy Wire

Framing, sheathing, subflooring, decking, lathing, door & window units, fencing, pallets, crate and box assembly, furring and furniture framing

Length	Item Code	Box Count	Point	Finish	Coating
1 1/2	Q17BRB	5.M	Chisel	Bright	Sencote
1 3/4	Q19BRB	5.M	Chisel	Bright	Sencote
2	Q21BRB	5.M	Chisel	Bright	Sencote
2 1/4	Q23BRB	5.M	Chisel	Bright	Sencote
2 1/2	Q25BRB	5.M	Chisel	Bright	Sencote
1 1/4	Q15BAB	5.M	Chisel	Class1 Galv	Sencote
1 1/2	Q17BAB	5.M	Chisel	Class1 Galv	Sencote
1 3/4	Q19BAB	5.M	Chisel	Class1 Galv	Sencote
2	Q21BAB	5.M	Chisel	Class1 Galv	Sencote
2 1/4	Q23BAB	5.M	Chisel	Class1 Galv	Sencote
2 1/2	Q25BAB	5.M	Chisel	Class1 Galv	Sencote
1 3/4	Q19BGBN	2.2M	Chisel	Stainless	Sencote
2 1/2	Q25BGBN	1.M	Chisel	Stainless	Sencote

Note: Class1 Galv. finish is required to meet most building code requirements.