



ROOFING PRODUCTS CATALOG

COMPLETE ROOFING TORCH KITS

SOLDERING IRON KIT

SEAMER KITS

MODIFIED BITUMEN APPLICATORS

ROOF DRYERS

CYLINDER DOLLIES

ROOFING TOOLS

PARTS & ACCESSORIES

PROPANE INFORMATION



FLAME ENGINEERING, INC.

Manufacturer of Red Dragon Roofing Torches & Equipment.

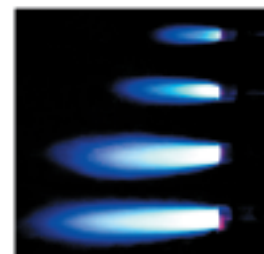

Catalog #0307

The Right Tools for the Trade!

From the development of a single, hand-held farm torch over 45 years ago, to over 100 products which serve many industries today, Flame Engineering combines simplicity, function, practicality and affordability to create some of the most unique products available.

Our top priority has always been Red Dragon Torches and flaming equipment. We are the first manufacturer ever to receive American Gas Association and Canadian Gas Association certification on hand-held torch kits used with a remote fuel supply. Throughout the years, Flame Engineering has been at the front lines, developing new products and listening to the people who use them. Our patented Liquid Propane Spray process, for example, provided more flame length, width and volume than vapor torches or the old coil-type liquid torches could offer. More recently, the Row Crop and Grapevine Berm Flamers are the only systems in the agricultural sector today which utilize our unique vaporizing liquid torch designs. No other manufacturer offers such a diverse line which serves the needs of all.

In addition to torches, Flame Engineering developed the highly successful engine pre-heater for Alaskan bush pilots. We now sell the same heaters across the United States and Canada. Again answering our customers' requests, we manufactured an extremely durable Hot Box construction heater which is now accompanied with seven other models. Our Patio Lights are unique, backyard products which are copied by others, but never equaled. Its elegance continues to delight homeowners, restaurants, resorts and outdoor enthusiasts.

We design eternal flame systems for museums, cemeteries and memorial sites. From an Olympic look to a more somber, memorial flame, Flame Engineering's goal is to provide the customer with just the right appearance and flame pattern. On a grander scale, the propane flare used to evacuate liquid and vapor tanks for valve change-outs, re-certifications or emergency flare-offs, has been well received in Canada and the U.S. With flame sensing and complete safety shutdown in case of a flame-out, we combine high capacity flaring with convenience and safety, making it a very unique product in the propane and emergency industries.

In order to be successful, we believe that the product must be easy to sell at the distributor level and reliable at the customer level. In addition, we provide a good deal of advertising, internet information and toll free customer service to support our distributors and inform the end users. We welcome your comments and suggestions and look forward to hearing from you.

Call us at **800-255-2469!**

Members Of:

- **National Propane Gas Association**
- **Western States Roofing Contractors Association**
- **Midwest Roofing Contractors Association**
- **Western Kansas Manufacturers Association**
- **Mid-American Manufacturing Technology Center**
- **National Association of Manufacturers**



The Complete Red Dragon Roofing Products Catalog

About The Red Dragon Roofing Products Catalog

We are pleased to introduce this new, full color, Roofing Products Catalog. We have always been advocates of safe practices while using torches on the roof and would like to call your attention to the important Safety Data on page 20. Also, call and ask for our FREE video presentation, "On the Roof Safety With Propane Torches." And don't forget that 11 Red Dragon Roofing Torch Kits are CSA* Certified so you know you are getting the safest, most reliable torch kits on the market today.

Please note, we have also improved the Red Dragon Roof Dryerfound on page 10. It now has even more drying power with a larger horsepower engine and higher rpm blower.

Attention Red Dragon Distributors

Helping our distributors is a top priority and we continue to do this in a number of ways. Flame Engineering promotes Red Dragon products through an extensive advertising plan and aggressive trade show participation. We encourage you to advertise! We have a complete photography file of our products on CD-Rom, available to anyone wishing to advertise or include Red Dragon products in their catalog. Please call today for more information about co-op advertising or a free copy of our product photo CD.

Thank you for choosing RED DRAGON!



*** CSA International (formerly the American Gas Association and Canadian Gas Association) is an independent testing laboratory specializing in LP and Natural Gas Equipment for the United States and Canada. Flame Engineering was the first torch manufacturer to receive both American Gas Association and Canadian Gas Association certification.**

TABLE OF CONTENTS

Roofing Torch Kits2 - 6
Soldering Iron Kit6
Seamer Kits7
Modified Bitumen Applicators8 - 9
Roof Dryers10
Cylinder Dollies11
Infrared Non-Contact Thermometers11
Roofing Tools12 - 13
Spud Bars12
Core Cutter12
Bitumen Hooker13
Roll Hook13
Roofing Trowels13
Spark Lighter13
Roofing Torch Parts And Accessories14 - 18
Replacement Torches14
Piezo Ignitors15
Squeeze Valve16
Quick Connector16
P.O.L.'s16 - 17
M.O.P.'s17
Needle Valves17
Adapters & Couplings17
Pressure Gauge18
Regulators18
LP Gas Hose18
Torch Kits, SPA Wagon and Roof Dryer Assembly Diagrams18 - 19
Propane Properties And Safety Data20

- ▶ **RED DRAGON TORCHES** are made of durable, lightweight steel and contain all parts necessary to torch down modified bitumen.
- ▶ Each product is tested prior to leaving the factory and is guaranteed in quality and workmanship.
- ▶ We stock a complete line of parts and accessories available for immediate delivery, all of which include standard American fittings.

RED DRAGON RT COMBO

Other manufacturers have unsuccessfully attempted to copy the **RT COMBO**. This kit is truly the choice of professional roofers. Be certain to ask for all kits by name and number and you'll be sure to receive genuine **RED DRAGON TORCHES** – the best tools for the trade.

This combination field and detail torch kit is our most popular model. The handy quick connect feature enables the operator to switch from stand-up to detail torch in a snap – without tools and while still using the same LP gas hose, regulator and tank.

CSA Certified for U.S and Canada.

Also available in a Lightweight Model – RT Combo LW.

KIT INCLUDES:

Qty	Part #	Description
1	RT 2 ¹ / ₂ -20	400,000 BTU Field Torch w/Male Quick Connect Adaptor
	or RT 2 ¹ / ₂ -20 LW	400,000 BTU Field Torch w/Male Quick Connect Adaptor
1	RT 1 ¹ / ₂ -10	50,000 BTU Detail Torch w/Male Quick Connect Adaptor
<small>(see Replacement Parts and Accessories for Torch Components)</small>		
1	HN-5	U.L. Listed Female Quick Connect
1	HP-25	U.L. Listed 25' LP Gas Hose
1	567 RC	U.L. Listed Regulator
1	P-W 795	U.L. Listed Hand Tighten POL
1	G-23	Pressure Gauge
2	TB-4	Welded Torch Stand
1	L-2001	Spark Lighter and Flints

Order SKU #	Wt Each	Case Qty
RT COMBO	9.3 lbs	4
RT COMBO LW	9.0 lbs	4



The **QUICK CONNECT** feature allows the operator to instantly switch from stand-up to detail torch with no tools while continuing to use the same LP gas hose, regulator and tank!

RED DRAGON RT 2¹/₂-20 C



KIT INCLUDES:

Qty	Part #	Description
1	RT 2 ¹ / ₂ -20	400,000 BTU Field Torch
	or RT 2 ¹ / ₂ -20 LW	400,000 BTU Field Torch
<small>(see Replacement Parts and Accessories for Torch Components)</small>		
1	HP-25	U.L. Listed 25' LP Gas Hose
1	567 RC	U.L. Listed Regulator
1	P-W 795	U.L. Listed Hand Tighten POL
1	G-23	Pressure Gauge
1	TB-4	Welded Torch Stand
1	L-2001	Spark Lighter and Flints

Order SKU #	Wt Each	Case Qty
RT 2 ¹ / ₂ -20 C	8.5 lbs	4
RT 2 ¹ / ₂ -20 LW C	8.2 lbs	4

The work horse of all Red Dragon roofing torch kits, the RT 2¹/₂-20 C performs stand up work with ease and is noted for durability and efficiency on the job. This kit excels in balance and flame control and has an overall torch length of 29." One size fits all!

CSA Certified for U.S and Canada.

Also available in a Lightweight Model – RT 2¹/₂-20 LW C.

In recent tests, the **RED DRAGON RT 2¹/₂-20 C** proved to be as hot or hotter than any competitive brand and capable of exceeding 400,000 BTU!





RED DRAGON HSB-25 C / HSH-25 C HEAD START KITS



The HSB-25 C features a Piezo ignitor on the torch bell for a quick start every time.



The HSH-25 C features a Piezo ignitor near the handle for a quick start every time.

These two kits are each equipped with a Piezo ignitor for a quick start, time after time. Requires no electrical input – just push the ignitor button located on the torch head (HSB-25 C) or near the torch handle (HSH-25 C).

CSA Certified for U.S and Canada.

KIT INCLUDES:

Qty	Part #	Description
1	HSB-25	400,000 BTU Field Torch w/Ignitor on Torch Bell
	or HSH-25	400,000 BTU Field Torch w/Ignitor on Handle
(see Replacement Parts and Accessories for Torch Components)		
1	HP-25	U.L. Listed 25' LP Gas Hose
1	567 RC	U.L. Listed Regulator
1	P-W 795	U.L. Listed Hand Tighten POL
1	G-23	Pressure Gauge
1	TB-4	Welded Torch Stand

Order SKU #	Wt Each	Case Qty
HSB-25 C	7.5 lbs	4
HSH-25 C	7.5 lbs	4

RED DRAGON RT TWIN C

This power house is perfect for the roofer who prefers the high, 600,000 BTU output of the dual VT 2 1/2-0 burner system. This durable and very effective kit is sure to increase productivity and is still very affordable. (May require a 100 lb. or larger LP Cylinder).

CSA Certified for U.S and Canada.



KIT INCLUDES:

Qty	Part #	Description
1	RT Twin	600,000 BTU Field Torch w/Ignitor on Torch Bell
(see Replacement Parts and Accessories for Torch Components)		
1	HP-25	U.L. Listed 25' LP Gas Hose
1	567 RC	U.L. Listed Regulator
1	P-W 795	U.L. Listed Hand Tighten POL
1	G-23	Pressure Gauge
1	TB-4	Welded Torch Stand
1	L-2001	Spark Lighter and Flints



The Twin Heads produce 600,000 BTU allowing you to handle those special jobs which require wider flame coverage and more heat output.

Order SKU #	Wt Each	Case Qty
RT TWIN C	9.4 lbs	4



All torch kits listed on pages 2 & 3 are CSA Certified for the U.S. & Canada.

All RED DRAGON Torches Are



TO PLACE AN ORDER:
Contact Your Local RED DRAGON Roofing Distributor
or Call Flame Engineering, Inc. Today!

800-255-2469

RED DRAGON RT 3-20 C

This heavy duty kit is perfect for the roofer who requires higher BTU output. At 500,000 BTU this kit increases flame width, length and overall heat coverage with a single torch head.

CSA Certified for U.S and Canada.

KIT INCLUDES:

Qty	Part #	Description
1	RT 3-20	500,000 BTU Field Torch w/Ignitor on Torch Bell
(see Replacement Parts and Accessories for Torch Components)		
1	HP-25	U.L. Listed 25' LP Gas Hose
1	567 RC	U.L. Listed Regulator
1	P-W 795	U.L. Listed Hand Tighten POL
1	G-23	Pressure Gauge
1	TB-4	Welded Torch Stand
1	L-2001	Spark Lighter and Flints



Order SKU #	Wt Each	Case Qty
RT 3-20 C	8.1 lbs	4

RED DRAGON RT BASIC



The RT Basic is available for the price conscious roofer who wants a great torch but the very basic requirements in features and accessories. P.O.L. fitting requires wrench tightening, no pressure gauge, and no spark lighter included.

CSA Certified for U.S and Canada.

KIT INCLUDES:

Qty	Part #	Description
1	RT 2 1/2-20 LW	500,000 BTU Field Torch w/Ignitor on Torch Bell
(see Replacement Parts and Accessories for Torch Components)		
1	HP-25	U.L. Listed 25' LP Gas Hose
1	567 RC	U.L. Listed Regulator
1	P-3200 W	U.L. Listed Safety POL
1	TB-4	Welded Torch Stand

Order SKU #	Wt Each	Case Qty
RT BASIC	7.2 lbs	4

All RED DRAGON Torches Are



All torch kits listed on pages 4 & 5 are CSA Certified for the U.S. & Canada.

SAFETY FIRST!

At Flame Engineering, Inc., we promote the safe use of all our products. Call or write for your **FREE Safety Video** entitled "On The Roof Safety With Propane Torches." This is a must-see video for new roofing employees and is a great reminder for veteran roofers. Implement this video into your safety program today. No purchase necessary.



RED DRAGON RT 1 1/2-10 C DETAIL TORCH KIT

Need a detail torch to make easy work around flashings, walls, and other obstacles? Ask for the RT 1 1/2-10 C torch kit. Overall length is 15", the preference of professional roofers today. Use this kit with one of our hand trowels (TW-5 & TW-7 on page 13) for easy patch work and cleanup.

CSA Certified for U.S and Canada.



KIT INCLUDES:

Qty	Part #	Description
1	RT 1 1/2-10	50,000 BTU Detail Torch
<small>(see Replacement Parts and Accessories for Torch Components)</small>		
1	HP-25	U.L. Listed 25' LP Gas Hose
1	567 RC	U.L. Listed Regulator
1	P-W 795	U.L. Listed Hand Tighten POL
1	G-23	Pressure Gauge
1	TB-4	Welded Torch Stand
1	L-2001	Spark Lighter and Flints

Order SKU #	Wt Each	Case Qty
RT 1 1/2-10 C	7.0 lbs	4



IMPORTANT NOTE:
WE DON'T MANUFACTURE HOT AIR TORCHES FOR THIS REASON; Visible or invisible, heat can be dangerous if not used safely and properly. All hot air torches generate sufficient heat to burn if left in one place long enough. We promote the safe use of all torches.

RED DRAGON RK 5-10 C ROOF PATCH KIT

For small spot repairs, reach for the RK 5-10 C Roof Patch Kit. A handy kit for quick fix-ups. Compact and easily carried up a ladder. Comes complete with a 5 lb. capacity cylinder. **CSA Certified for U.S and Canada.**



KIT INCLUDES:

Qty	Part #	Description
1	RT 1 1/2-10	50,000 BTU Detail Torch
<small>(see Replacement Parts and Accessories for Torch Components)</small>		
1	C-6	5 lb. LP Gas Cylinder
1	HP-10	U.L. Listed 10' LP Gas Hose
1	567 RC	U.L. Listed Regulator
1	P-W 795	U.L. Listed Hand Tighten POL
1	G-23	Pressure Gauge
1	TB-4	Welded Torch Stand
1	L-2001	Spark Lighter and Flints

Order SKU #	Wt Each	Case Qty
RK 5-10 C	7.0 lbs	1



The RK 5-10 C is compact and easily carried up a ladder.

TO PLACE AN ORDER:
Contact Your Local RED DRAGON Roofing Distributor
or Call Flame Engineering, Inc. Today!

800-255-2469

RED DRAGON RT 2 1/2-20 CDX

A complete roofing torch kit, the CDX model includes both stand-up and detail heads (tools required for changing heads). Whenever changing torch heads, please remember to use thread sealant or compound to ensure a safe transition.

Also available in a Lightweight Model - RT 2 1/2-20 LW CDX.



KIT INCLUDES:

Qty	Part #	Description
1	RT 2 1/2-20	400,000 BTU Field Torch
	or RT 2 1/2-20 LW	400,000 BTU Field Torch
<small>(see Replacement Parts and Accessories for Torch Components)</small>		
1	VT 1 1/2-0	50,000 BTU Detail Torch Head
1	ET-4	4" Torch Extension
1	HP-25	U.L. Listed 25' LP Gas Hose
1	567 RC	U.L. Listed Regulator
1	P-W 795	U.L. Listed Hand Tighten POL
1	G-23	Pressure Gauge
1	TB-4	Welded Torch Stand
1	L-2001	Spark Lighter and Flints

Order SKU #	Wt Each	Case Qty
RT 2 1/2-20 CDX	9.0 lbs	4
RT 2 1/2-20 LW CDX	8.4 lbs	4

RED DRAGON ST 1-12 C PROPANE SOLDERING IRON

The Red Dragon Soldering Iron kit stays hot, enabling you to solder consistently and quickly. No electricity or acetylene bottles necessary here – just a one-gallon propane cylinder. Each kit is equipped with a Diamond Point Tip. Optional Chisel Point Tip available upon request. Solder flashings, gutters, copper, and more with the ST 1-12 C.



The ST 1-12 shown with optional ST-13 Chisel Point Tip and standard ST-11 Diamond point tip. Please specify upon ordering.

KIT INCLUDES:

Qty	Part #	Description
1	ST 1-12	25,000 BTU Soldering Iron Assembly
1	ST-11	Diamond Point Tip
1	HP-10	U.L. Listed 10' LP Gas Hose
1	567 RC	U.L. Listed Regulator
1	V-334	Flame Adjusting Valve
1	P-3200 W	Soft Nose Excess Flow POL
1	G-23	Pressure Gauge
1	ST 1-B	Welded Torch Stand
•	Optional ST-13	Chisel Point Tip

Order SKU #	Wt Each	Case Qty
ST 1-12 C Soldering Kit	7.2 lbs	4
ST-11 Diamond Point Tip	0.4 lbs	1
ST-13 Chisel Point Tip	0.4 lbs	1

All RED DRAGON Torches Are



TO PLACE AN ORDER:
 Contact Your Local **RED DRAGON** Roofing Distributor
 or Call Flame Engineering, Inc. Today!

800-255-2469

RED DRAGON SS 500 C SIMPLE SEAMER



The Red Dragon Simple Seamer allows you to finish seams from a standing position. No more back fatigue caused by all that stooping and bending with a hand trowel and hand torch. The lightweight Simple Seamer features a 50,000 BTU heated trowel with a dual grip handle to ensure ease in use. It is perfect for reheating laps, finishing seams, degranulating, filling voids or loose areas, and reheating seams. Torch position and trowel angle are adjustable and the squeeze valve gives you full control of the torch while you work.

KIT INCLUDES:

Qty	Part #	Description
1	SS 500	50,000 BTU Torch Assembly
1	HP-25	U.L. Listed 25' LP Gas Hose
1	567 RC	U.L. Listed Regulator
1	P-W 795	U.L. Listed Hand Tighten POL
1	V-880 P	Squeeze Valve
1	G-23	Pressure Gauge
1	L-2001	Spark Lighter and Flints

Order SKU #	Wt Each	Case Qty
SS 500 C	10.8 lbs	1



The Simple Seamer allows you to finish seams from a standing position, reducing back fatigue.

RED DRAGON SP1-6A MASTER SEAMER

Use the Red Dragon Master Seamer on jobs where a wagon is awkward and a precision seam weld is critical. The Master Seamer is designed to apply torchable modified bitumen asphalt. Originally designed for insulated membranes. Consult your materials manufacturer for more information on proper installation of your system.

The Red Dragon Master Seamer is very user friendly. It reduces stooping, troweling and hand torching seams by raising the membrane, torching the underside of the seam and then finishing the weld with our special "trailing" wheels. Each unit is packed partially assembled.



KIT INCLUDES:

Qty	Part #	Description
1	MS 1 1/2-0	50,000 BTU Torch Assembly
1	HP-25	U.L. Listed 25' LP Gas Hose
1	567 RC	U.L. Listed Regulator
1	P-W 795	U.L. Listed Hand Tighten POL
1	V-880 P	Squeeze Valve
1	G-23	Pressure Gauge
1	L-2001	Spark Lighter and Flints

Order SKU #	Wt Each	Case Qty
SP1-6A	38.0 lbs	1

The Master Seamer raises the membrane, torches the underside of the seam and finishes the weld with special "trailing" wheels. Also, just a simple turn of the "T" handle and the torch reverses to work the opposite side of the roll.

RED DRAGON Seamers Are

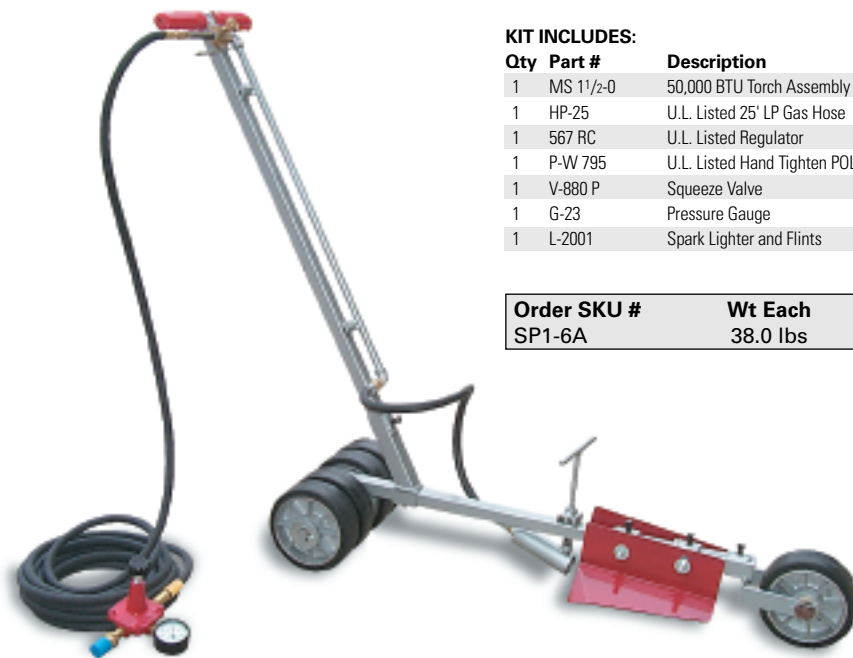

- ▶ **RED DRAGON MODIFIED BITUMEN APPLICATORS CAN GREATLY REDUCE APPLICATION TIME!**
- ▶ **ARE MADE OF DURABLE, LIGHTWEIGHT STEEL CONSTRUCTION . ▶ APPLY 3/4, 1 AND 1 1/2 SQUARE ROLLS.**
- ▶ **BUY 3 AND WE'LL ASSEMBLE THEM FREE OF CHARGE**
(3 assembled units ship by truck only, in one box)

RED DRAGON SPA 540 A & SPA 740 A MODIFIED BITUMEN APPLICATORS

Both the Red Dragon SPA 540 A (5 burners) & SPA 740 A (7 burners) feature one-handle design and complete manifold adjustability, making these wagons the most requested in the industry. Each torch has a flame adjusting needle valve for total flame control and the manifold moves to and from the roll with a simple twist of the handle. The manifold angle can also be adjusted and side shields and superior design concentrate the heat on the material – not the operator. Use on APP systems.



SPA-540 A

SPA-740 A

THE FIRST CHOICE OF PROFESSIONAL ROOFING CONTRACTORS!

UNIT INCLUDES:

Qty	Part #	Description
5 or 7	VT 2 1/2-0	400,000 BTU Vapor Torch Head
5 or 7	V 3055 P	Flame Adjusting Needle Valve
1	HP-25	U.L. Listed 25' LP Gas Hose
1	567 RC	U.L. Listed Regulator
1	P-1685	U.L. Listed PDL
1	V-880 P	Squeeze Valve
1	G-23	Pressure Gauge
1	L-2001	Spark Lighter

Order SKU #	Wt Each	Case Qty
SPA-540 A	82.0 lbs	1
SPA-740 A	84.0 lbs	1

(shipped in 2 boxes)

Torch and manifold adjustments are easily made on the SPA 540 A & 740 A. Each torch has a needle valve, and the manifold moves back and forth by rotating the handle.

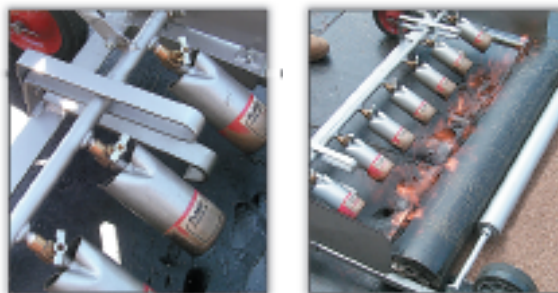

Now apply bitumen with the trailing wheels on or off the roll.

SPA-540 A & SPA-740 A both feature the easy roll mounting system. As Easy as One, Two, Three!

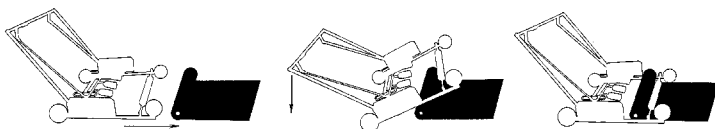

This NEW design allows the trailing wheels to be assembled inside or outside the frame on the SPA-540 A & SPA-740 A, as some modified bitumen manufacturers specify no wheels on the seam.

RED DRAGON SPA 1000 MODIFIED BITUMEN APPLICATOR



By customer request we are offering a new wagon similar to a competitor's model. The older style two handle design modernized by Red Dragon technology. Features include a stainless steel manifold and framework and 7 durable vapor torches. Each torch has a flame adjusting needle valve for total flame control and the manifold easily moves to and from the roll. Lighter weight than the competition and American made. For use by professional roofing contractors.

UNIT INCLUDES:

Qty	Part #	Description
2	VT 2 1/2-0	400,000 BTU Vapor Torch Head
5	VT 2-0	100,000 BTU Vapor Torch Head
7	V 3055 P	Flame Adjusting Needle Valve
1	HP-50	U.L. Listed 50' LP Gas Hose
1	R-499	U.L. Listed Regulator
1	P-1685	U.L. Listed POL
1	V-880 PH-1	Squeeze Valve/Handle Assembly
1	G-23	Pressure Gauge

Order SKU #	Wt Each	Case Qty
SPA-1000	54.0 lbs	1

RED DRAGON SPA-520 ECONOMY MODIFIED BITUMEN APPLICATOR

With five adjustable torches on a stationary manifold, the SPA 520 features one-handle design and a spool-type roller bar. This drag unit is the economy model of the line.

UNIT INCLUDES:

Qty	Part #	Description
5	VT 2 1/2-0	400,000 BTU Vapor Torch Head
5	V 3055 P	Flame Adjusting Needle Valve
1	HP-25	U.L. Listed 25' LP Gas Hose
1	567 RC	U.L. Listed Regulator
1	P-1685	U.L. Listed POL
1	V-880 P	Squeeze Valve
1	G-23	Pressure Gauge



All RED DRAGON Modified Bitumen Applicators Are



Order SKU #	Wt Each	Case Qty
SPA-520	57.3 lbs	1

(shipped in 1 box)

TO PLACE AN ORDER:
Contact Your Local **RED DRAGON** Roofing Distributor
or Call Flame Engineering, Inc. Today!

800-255-2469

- ▶ SAVE LABOR ▶ EASY TO OPERATE ▶ REMOVE FROST & DEW ▶ SAFE, NO ELECTRICITY REQUIRED
- ▶ DRY WET SURFACES ▶ REDUCE COSTLY DOWN TIME ▶ CLEAR LIGHT DEBRIS



NEW MODEL HAS MORE HORSEPOWER!

5 HP HONDA ENGINE

"HURRICANE MINUTEMAN" BLOWERS

250,000 BTU Burner



Red Dragon Roof Dryers combine high heat and a powerful blower to dry roofs quickly.

UNIT ALSO INCLUDES:

Qty	Part #	Description
1	VT 3-12 S	250,000 BTU Vapor Torch Head
1	HP-25	U.L. Listed 25' LP Gas Hose
1	P-3200	U.L. Listed POL Fitting
1	V-880 P	Squeeze Valve
1	R-700 C	18 P.S.I. Regulator

RED DRAGON RD 6005 ROOF DRYER

The RED DRAGON RD 6005 Roof Dryer defrosts, dries and get you back on the job with minimum effort. Its rugged design and user friendly features make it the perfect choice for professional roofing contractors. Use to dry surfaces after ponding water has been removed or to remove morning dew, frost or light debris.



The Roof Dryers work by combining high heat (up to 350° F) and a 200 MPH airstream to facilitate quick drying and reduce costly downtime. No electrical cords or danger of electrical shock. Rely on Red Dragon Roof Dryers when mother nature tries to delay your work day.

Blower Specification RD 6005:

5 HP Honda GC Overhead Cam Premium 4-cycle engine with recoil start. Powerful 200 MPH airstream, up to 1600 cubic feet per minute.

Heating System Specifications:

VT 3-12 S burner, up to 250,000 BTU/hr, mixes with air to provide the desired drying effect up to 350° F.

Order SKU #	Wt Each	Case Qty
RD 6005 (Honda)	125.0 lbs	1

TO PLACE AN ORDER:
 Contact Your Local **RED DRAGON** Roofing Distributor
 or Call Flame Engineering, Inc. Today!

800-255-2469



CD-100 Cylinder Dolly

The CD-100 Cylinder Dolly makes the perfect companion for any Red Dragon torch kit and is ideally suited for LP Gas cylinders up to 40 pounds (10 gallons). The single handle allows the operator to use a torch and move the dolly simultaneously. When the torch is not in operation, it can be stored on the convenient torch bracket.

The rugged CD-100 is welded tubular steel, with two seven-inch wheels and a solid 5/8" axle assuring years of dependable use. Maximum load capacity is 100 pounds (cylinder not included).

Order SKU #	Wt Each	Std Qty
CD-100	13.9 lbs	1

CD-505 Cylinder Dolly

The RED DRAGON CD-505 Cylinder Dolly is specifically designed for transporting 100 pound cylinders. The ergonomic design features handles that are set wide and angled outward, making it easy to push, pull, or turn.

The CD-505 is constructed of heavy gauge square tubing. It features removable, two-ply pneumatic tires mounted on steel wheels with heavy duty roller bearings on a 1" steel axle.

Order SKU #	Wt Each	Std Qty
CD-505	37.2 lbs	1



The CD-100 is the perfect companion for any Red Dragon Torch Kit.

All RED DRAGON Cylinder Dollies Are



RED DRAGON GT-1000 & GT-2000 NON-CONTACT INFRARED THERMOMETERS

- ▶ **QUICKLY, SAFELY & ACCURATELY CHECK FOR HOT SPOTS ON ANY ROOF.**
- ▶ **PRECISE NON-CONTACT MEASUREMENTS. ▶ 8:1 DISTANCE TO SPOT RATIO.**
- ▶ **DATA HOLD & AUTO POWER OFF. ▶ BUILT IN LASER POINTER.**
- ▶ **F°/C° SWITCHABLE BUTTON. ▶ BACKLIT LCD DISPLAY.**



The GT-1000 and GT-2000 are perfect safety tools for all roofing crews. Quickly check the temperature of the roof where material has been applied. A great safety step at the end of the day. Both units are very accurate and simple to use. Just point, pull the trigger, and read the temperature on the display!

The GT-2000 features a larger temperature range plus the option of using a plug in K-Type thermocouple touch probe to take temperatures by physically touching the object or surface. Good for taking immersion temperatures of liquids.

Order SKU #	Wt Each	Case Qty
GT-1000	0.8 lbs	1
GT-2000	1.0 lbs	1

GT-1000 Features:

Temperature Range: -4°F to 518°F (-20°C to 270°C)
 Accuracy: Approximately 2% of reading or ±4°F / ±2°C
 Distance (D) to Spot Size (S) Ratio = 8:1
 Fixed Emissivity: Σ = 0.95
 Complete with 9V battery.

GT-2000 Features:

Temperature Range: 0°F to 1832°F (-18°C to 1000°C)
 Accuracy: Approximately 2% of reading or ±4°F / ±2°C
 Distance (D) to Spot Size (S) Ratio = 8:1
 Adjustable Emissivity: 0.3 to 0.99
 K-Type Temperature Range: -40°F to 2192°F (-40°C to 1200°C)
 K-Type Temperature Accuracy: ±0.5% of reading ±3°F (2°C)

GT-2000 Comes complete with:

- 9V battery
- K-Type Thermocouple Temperature Probe
- Wrist Strap
- Carrying Case



RED DRAGON SBL & SBD SPUD BARS

RED DRAGON Spud Bars are heavy duty and built for durability. Each spud bar is robot welded to ensure the finest quality. Replaceable blades are made from Tempered Blue Spring Steel (Rockwell C-44 Hardness)

Available with 3 1/2" or 7" replaceable blades. Handles are four feet in length with your choice of ball or D-shaped handle for maximum leverage.

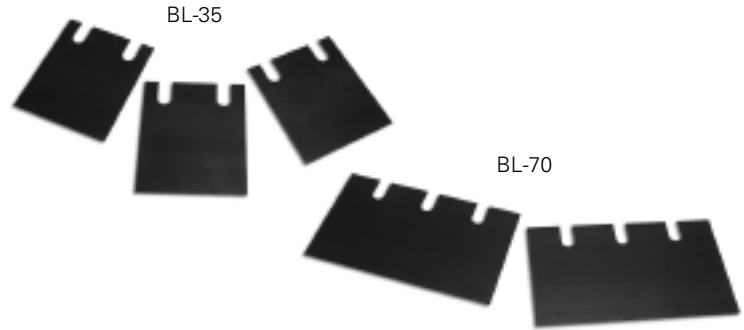

Description	Order SKU #	Wt Each	Std Qty
3 1/2" Blade/Ball Handle	SBL-35	6.5 lbs	9
7" Blade/Ball Handle	SBL-70	8.2 lbs	6
3 1/2" Blade/D-Handle	SBD-35	7.0 lbs	9
7" Blade/D-Handle	SBD-70	8.5 lbs	6
3 1/2" Replacement Blade	BL-35	12 lbs/case	50
7" Replacement Blade	BL-70	23.5 lbs/case	50

RED DRAGON CC 501 CORE CUTTER

The RED DRAGON CC 501 Core Cutter is perfect for roofers, architects and engineers on the go. The CC 501 is fast and easy to use. Simply turn the core cutter into the roof, pull and you have your core sample. At 2 1/8" x 10 3/4", the CC 501 is small enough to fit your toolbox and is easy to assemble. The CC 501 extracts a 2" diameter x 7" sample.

All RED DRAGON Roofing Tools Are

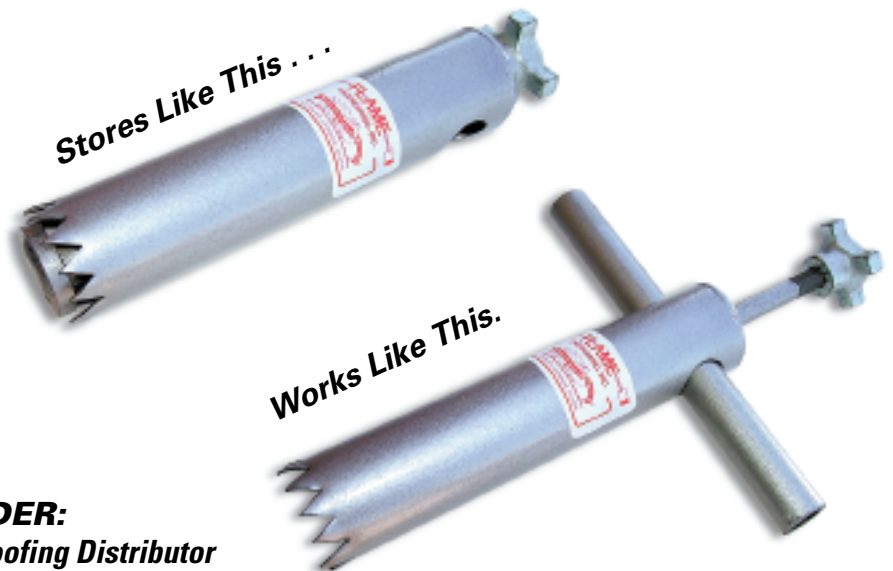

TO PLACE AN ORDER:
 Contact Your Local **RED DRAGON** Roofing Distributor
 or Call Flame Engineering, Inc. Today!

800-255-2469

Order SKU #	Wt Each	Std Qty
CC 501	5.0 lbs	1

RED DRAGON HH 6030 HOOKER

The RED DRAGON "Hooker" allows the operator to torch modified bitumen without walking on the membrane. It features a padded hook which wraps around the hips, reducing strain on the back and shoulders. The hook length is also adjustable to give any person the proper working distance from the roll. It may also be used to control the roll when applying modified to pitched roofs.

Order SKU #	Wt Each	Std Qty
HH 6030	9.0 lbs	1

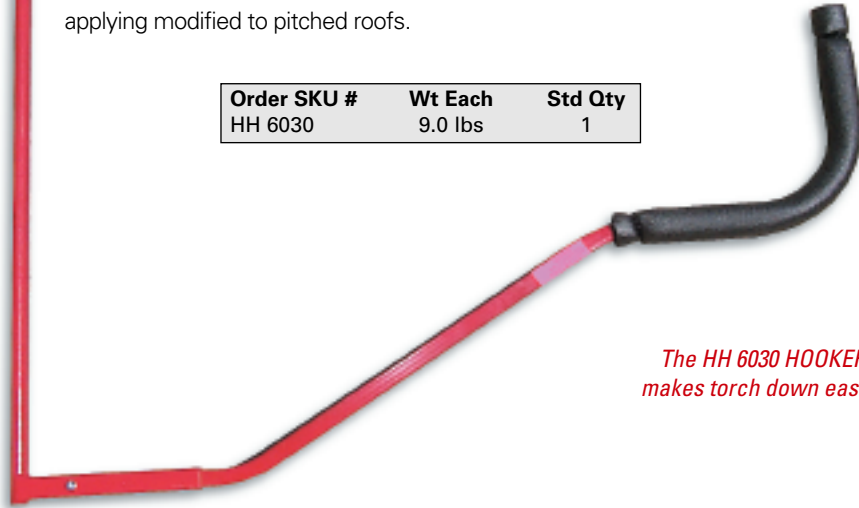

*The HH 6030 HOOKER
makes torch down easier.*



RED DRAGON HR-836 ROLL HOOK

This lightweight hook allows the roofer to hand torch rolls without walking on the membrane. Simply push or pull the roll as necessary. Perfect for use with Red Dragon Roofing Torch Kits. Overall hook length is 36 inches.



Order SKU #	Wt Each	Std Qty
HR-836	9.0 lbs	1

RED DRAGON ROOFING TROWELS

These round nosed trowels feature polished, tempered steel blades and a durable hardwood handle. Available with 5" and 7" blades. Perfect for use with Red Dragon Detail Torches.



Order SKU #	Wt Each	Std Qty
TW-5 (5" Blade)	0.3 lbs	12
TW-7 (7" Blade)	0.5 lbs	12

L 2001 SPARK LIGHTER

The convenient and safe way to light LP Gas torches. The L 2001 Spark Lighter produces up to 1,500 ignitions per flint and comes with a free 5 pack of replacement flints.

Order SKU #	Wt Each	Std Qty
L 2001	0.2 lbs	10
L 2012 (pack of 5 flints)	0.03 lbs	24



RT 2 1/2-20 ROOFING TORCH

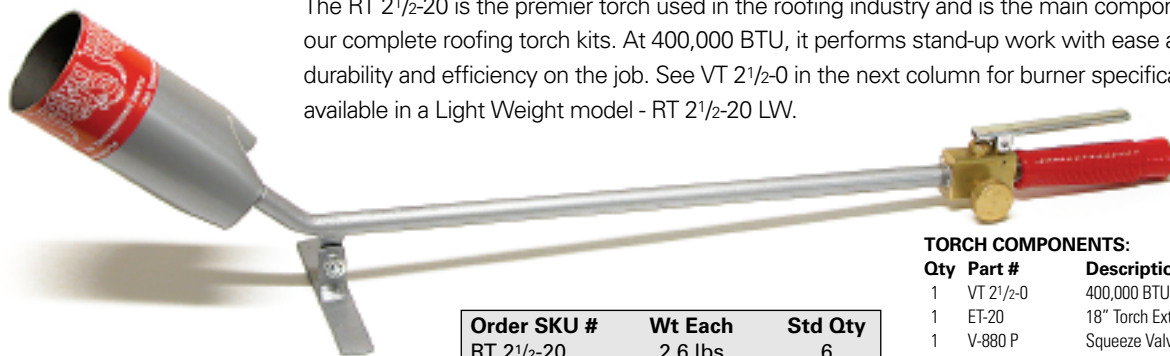

The RT 2 1/2-20 is the premier torch used in the roofing industry and is the main component in most of our complete roofing torch kits. At 400,000 BTU, it performs stand-up work with ease and is noted for durability and efficiency on the job. See VT 2 1/2-0 in the next column for burner specifications. Also available in a Light Weight model - RT 2 1/2-20 LW.

Order SKU #	Wt Each	Std Qty
RT 2 1/2-20	2.6 lbs	6
RT 2 1/2-20 LW	2.3 lbs	6

TORCH COMPONENTS:

Qty	Part #	Description
1	VT 2 1/2-0	400,000 BTU 2 1/2" Diameter Torch Head
1	ET-20	18" Torch Extension
1	V-880 P	Squeeze Valve w/Adjustable Pilot
1	H-1	Rubber Grip Handle
1	TB-4	Torch Stand

RT 1 1/2-10 DETAIL ROOFING TORCH

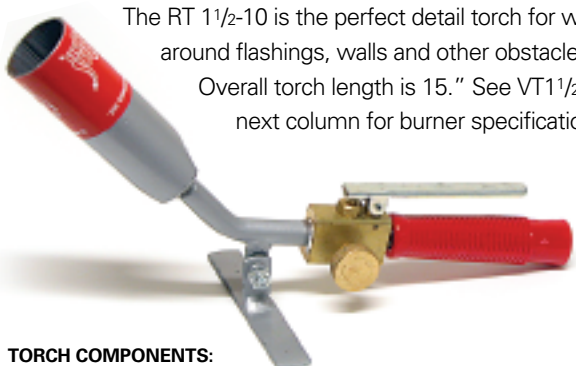

The RT 1 1/2-10 is the perfect detail torch for work around flashings, walls and other obstacles. Overall torch length is 15." See VT 1 1/2-0 in the next column for burner specifications.

TORCH COMPONENTS:

Qty	Part #	Description
1	VT 1 1/2-0	50,000 BTU 1 1/2" Diameter Torch Head
1	ET-4	4" Torch Extension
1	V-880 P	Squeeze Valve w/Adjustable Pilot
1	H-1	Rubber Grip Handle
1	TB-4	Torch Stand

Order SKU #	Wt Each	Std Qty
RT 1 1/2-10	1.25 lbs	6

VT 3-0 VAPOR TORCH

When an increased BTU output is desired, use this replacement torch on Red Dragon Roofing Torches and Red Dragon SPA Modified Bitumen Applicators.



Max Capacity	500,000 BTU	Max Fuel Consumption	23.2 lbs/hr
Normal Operating Pressure	30 PSIG	Fuel Inlet	1/4" NPT
Operating Pressure Range	5-90 PSIG	Bell Diameter	3 inches
Fuel Consumption @ 30 PSIG	10.13 lbs/hr	Bell Length	6 inches
Approximate Flame Temperature	2050°F		

Order SKU #	Wt Each	Std Qty
VT 3-0	1.2 lbs	6

VT 2 1/2-0 VAPOR TORCH

This is the standard replacement torch head for RT 2 1/2-20 torches and all Red Dragon SPA Modified Bitumen Applicators.



Max Capacity	400,000 BTU	Max Fuel Consumption	18.5 lbs/hr
Normal Operating Pressure	25 PSIG	Fuel Inlet	1/4" NPT
Operating Pressure Range	5-50 PSIG	Bell Diameter	2.5 inches
Fuel Consumption @ 30 PSIG	9.03 lbs/hr	Bell Length	5.5 inches
Approximate Flame Temperature	2050°F		

Order SKU #	Wt Each	Std Qty
VT 2 1/2-0	0.9 lbs	6
VT 2 1/2-0 LW	0.6 lbs	6

VT 2-0 VAPOR TORCH

This vapor torch will reduce the maximum BTU rating on Red Dragon roofing torches and SPA Modified Bitumen Applicators and increase BTU on the RT 1 1/2-10.



Max Capacity	100,000 BTU	Max Fuel Consumption	9.3 lbs/hr
Normal Operating Pressure	20 PSIG	Fuel Inlet	1/4" NPT
Operating Pressure Range	5-40 PSIG	Bell Diameter	2 inches
Fuel Consumption @ 30 PSIG	4.5 lbs/hr	Bell Length	5.5 inches
Approximate Flame Temperature	2050°F		

Order SKU #	Wt Each	Std Qty
VT 2-0	0.75 lbs	6

RED DRAGON Parts And Accessories Are



VT 1 1/2-0 VAPOR TORCH

This head is the standard replacement for the RT 1 1/2-10 torch.



Max Capacity	50,000 BTU	Max Fuel Consumption	3.1 lbs/hr
Normal Operating Pressure	10 PSIG	Fuel Inlet	1/4" NPT
Operating Pressure Range	5-25 PSIG	Bell Diameter	1.5 inches
Fuel Consumption @ 30 PSIG	2.25 lbs/hr	Bell Length	4.5 inches
Approximate Flame Temperature	2050°F		

Order SKU #	Wt Each	Std Qty
VT 1 1/2-0	0.5 lbs	6

ET-2B TWIN BURNER ADAPTOR

The ET-2B adaptor allows you to add a second burner to any Red Dragon Roofing Torch. Simply remove the burner from the torch, install the adaptor, then install the original burner and one additional burner at each elbow.



Order SKU #	Wt Each	Std Qty
ET-2B	0.4 lbs	6

ET-20 & ET-4 TORCH EXTENSIONS

The **ET-20** is 18" overall and is the standard tube connecting the valve to the torch head on all RT 2 1/2-20 torches. Connects with 1/4" MPT on each end. Comes complete with a TB-4 Torch Stand.

The **ET-4** is a 4" tube and is standard on all RT 1 1/2-10 torches. Connects with 1/4" MPT on each end. Comes complete with a TB-4 Torch Stand.



Order SKU #	Wt Each	Std Qty
ET-20	0.75 lbs	6
ET-4	0.3 lbs	6

H-1 TORCH HANDLE

A replacement handle for all Red Dragon Roofing Torches. Connects to the squeeze valve.



Order SKU #	Wt Each	Std Qty
H-1	0.25 lbs	10

TB-4 TORCH STAND

The TB-4 attaches to the extension tube of all Red Dragon Roofing Torches, supporting the torch while directing the flame upward when not in use. Bolt, nut and lockwasher included.



Order SKU #	Wt Each	Std Qty
TB-4	0.2 lbs	6

REPLACEMENT PIEZO IGNITORS

Replacement ignitors for Red Dragon Head Start Torch Kits HSB-25 C and HSH-25 C. Comes with either a mounting bracket for replacement on a HSB-25 or a 14" lead wire for replacement on a HSH-25.



Order SKU #	Wt Each	Std Qty
HSB-21 (for HSB-25 C)	0.2 lbs	6
Model 21 H (for HSH-25 C)	0.2 lbs	6

TO PLACE AN ORDER:

Contact Your Local **RED DRAGON** Roofing Distributor or Call Flame Engineering, Inc. Today!

800-255-2469

V-880 PH-1 – Squeeze Valve with Adjustable Pilot & Torch Handle Kit

The Red Dragon V-880 PH-1 allows you to add a squeeze valve and handle to any Red Dragon Vapor Torch Kit. Perfect for those who use a Red Dragon Torch Kit for roofing and instances where full flame is not continuously required. This kit will quickly pay for itself in propane savings if this is how you will primarily use the torch kit. The all-brass squeeze valve has an adjustable pilot feature. The adjustable pilot is a needle valve assembly similar to the Red Dragon V-334. This is a high pressure valve tested to 350 lbs working pressure.



Order SKU #	Wt Each	Std Qty
V-880 PH1	0.6 lbs	10

V-880 P SQUEEZE VALVE WITH ADJUSTABLE PILOT

This all brass squeeze valve features an adjustable pilot and is used on all Red Dragon Roofing Torches and Red Dragon Modified Bitumen Applicators. It is tested to 350 pounds of working pressure. 1/4" inlet – 1/4" outlet.

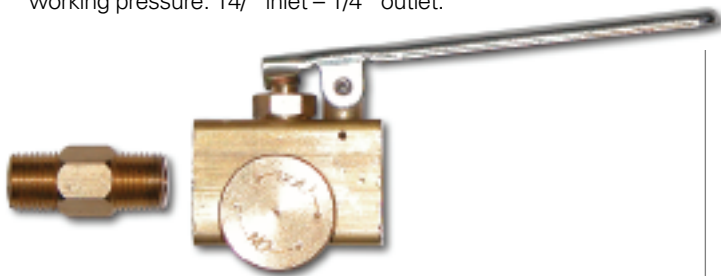

Order SKU #	Wt Each	Std Qty
V-880 P	0.6 lbs	10

VALVE REPAIR KITS AND LEVER ASSEMBLY FOR V-880 P

These 3 kits will allow you to repair either the pilot valve, the main valve or the lever assembly on any V-880 P Squeeze Valve.

TJP-123 PILOT VALVE REPAIR KIT **TC-42-7 MAIN VALVE REPAIR KIT**



Order SKU #	Wt Each	Std Qty
TJP-123 Pilot Valve Repair Kit	0.1 lbs	1
TC-42-7 Main Valve Repair Kit	0.1 lbs	1
TSTE 131-2 Lever Assembly	0.1 lbs	1

QUICK CONNECTOR SETS U.L. Listed

HK-8



HK-7



HN-5



HN-6



This brass set allows connection and disconnection of the LP-Gas line to the torch without the use of tools. The unique design of the HK-7 set makes coupling under pressure possible with minimal loss of fuel. Both pieces are 1/4" pipe thread (HN-5 female & HN-6 male). For use up to 250 PSI.

Order SKU #	Description	Wt Each	Std Qty
HK-8	complete set (2)HN-6 male (1)HN-5 female	0.53 lbs	10
HK-7	complete set (1)HN-6 male (1)HN-5 female	0.44 lbs	10
HN-5	female adaptor	0.25 lbs	10
HN-6	male adaptor	0.07 lbs	10

P-W 795 HAND TIGHTEN EXCESS FLOW P.O.L.

No wrenches needed with this soft nose P.O.L. It is all brass and can be hand-tighten for easy connection or disconnection from any LP-gas cylinder. The standard replacement fitting for most Red Dragon Roofing Torch Kits. Outlet is 1/4" MPT.



Order SKU #	Wt Each	Std Qty
P-W 795	0.3 lbs	10

P-3200 W SOFT NOSE EXCESS FLOW P.O.L.

This P.O.L. connection with integral excess flow check valve offers an ideal safety device for use on Red Dragon Roofing Torches, tar and asphalt burners and similar heating applications where portable LPG cylinders are used. The P.O.L. inlet end attaches directly to the outlet of the vapor cylinder valve while the outlet end is 1/4" MPT. Replacement P.O.L. for the RT Basic torch kit.



Order SKU #	Wt Each	Std Qty
P-3200 W	0.25 lbs	10

P-1685 STANDARD P.O.L. CONNECTION

The P-1685 adapts most LP cylinders to regulators and other fittings. The P.O.L. nut is the left hand fitting that threads into nearly all vapor butane/propane cylinders and the opposite end is standard 1/4" MPT. (No excess flow feature). Replacement P.O.L. for Red Dragon Modified Bitumen Applicators.



Order SKU #	Wt Each	Std Qty
P-1685	0.2 lbs	10

REPLACEMENT O RINGS FOR P.O.L.

Replacement O ring seals for P-1685, P-3200 W and P-W 795 P.O.L. fittings shown above.



Order SKU #	Case Wt	Case Qty
100-303-080	0.2 lbs	100

M 672-3 HAND TIGHTEN M.O.P.

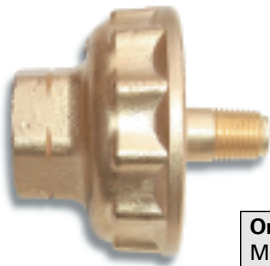

The M 672-3 is the standard fitting used to connect equipment to a liquid withdrawal cylinder. Hand tighten – no wrench necessary. **Use with liquid torches only.**

Order SKU #	Wt Each	Std Qty
M 672-3	1.1 lbs	10

M 7273 WRENCH TIGHTEN M.O.P.

Same as M 672-3 but must be tightened with a wrench. **Use with liquid torches only.**



Order SKU #	Wt Each	Std Qty
M 7273	0.5 lbs	10

V-334 FLAME ADJUSTING VALVE

The V-334 is a heavy duty, all brass needle valve tested to 350 P.S.I. It incorporates a thumb wheel for easy open or close. Inlet (female) and outlet (male) are 1/4" standard pipe thread.



Order SKU #	Wt Each	Std Qty
V-334	0.25 lbs	10

V-3055 FLAME ADJUSTING VALVE

A less expensive needle valve for use with LP-gas, air or water and other fluids. It incorporates an aluminum thumb wheel for easy open or close. Inlet (female) and outlet (male) are 1/4" standard pipe thread. This replaces the old V-3055 P needle valve with "T" handle.



Order SKU #	Wt Each	Std Qty
V-3055	0.2 lbs	10

9/16" LEFT HAND ADAPTER



Order SKU #	Description	Wt Each	Case Qty
F-825	1/4" MPT x 9/16" Left Hand	.1 lbs	10
F-835	3/8" MPT x 9/16" Left Hand	.1 lbs	10
F-855	9/16" Left Hand x 9/16" Left Hand	.1 lbs	10

1/4" FPT x 1/4" FPT HEX COUPLING



Order SKU #	Description	Wt Each	Case Qty
F-322	1/4" FPT x 1/4" FPT	.1 lbs	10

TO PLACE AN ORDER:
Contact Your Local **RED DRAGON** Roofing Distributor
or Call Flame Engineering, Inc. Today!

800-255-2469

567 RC & 567 RD REGULATORS

1/4" – Liquid or Vapor

U.L. Listed



567 RC

A medium capacity regulator with precise regulating characteristics, designed for cylinder systems in liquid or vapor service. Both the inlet and outlet of this regulator are 1/4" female pipe thread. The 567 RC is suitable for tar pot heaters, weed burners and other applications using either liquid or vapor cylinders. Delivery pressures are adjustable from 0 to 60 PSI. Plugged gauge port.

567 RD

The same characteristics and specifications as the 567 RC except the delivery pressures are adjustable from 0-100 PSI.

Order SKU #	Description	Wt Each	Case Qty
567 RC	Regulator for 0-60 PSI Delivery	1.2 lbs	6
567 RD	Regulator for 0-100 PSI Delivery	1.2 lbs	6

HP SERIES LP-GAS HOSE ASSEMBLIES

HP series hose is U.L. Listed for use with either vapor or liquid LP-gas and is available in 10', 25' and 50' lengths. Each hose is coupled with 1/4" male pipe thread fittings on both ends*. Maximum working pressure of this hose is 350 PSI with a burst test of 1750 PSI. Hose I.D. is 1/4". A 1/4" female brass coupling is included with each HP-25 and HP-50.



U.L. Listed

Order SKU #	Description	Wt Each	Case Qty
HP-10	10' Hose w/1/4" MPT on both ends	1.5 lbs	10
HP-25	25' Hose w/1/4" MPT on both ends	4.0 lbs	6
HP-50	50' Hose w/1/4" MPT on both ends	6.1 lbs	4

RED DRAGON Parts And Accessories Are



TO PLACE AN ORDER:

Contact Your Local **RED DRAGON** Roofing Distributor or Call Flame Engineering, Inc. Today!

800-255-2469

G-23 PRESSURE GAUGE



A rugged steel cased gauge showing pressures from 0-100 PSI. The 1/4" male pipe stem allows it to be mounted on the 567 RC, 567 RD and R-499 regulators. Dial diameter is two inches.

Order SKU #	Wt Each	Std Qty
G-23	0.2 lbs	10

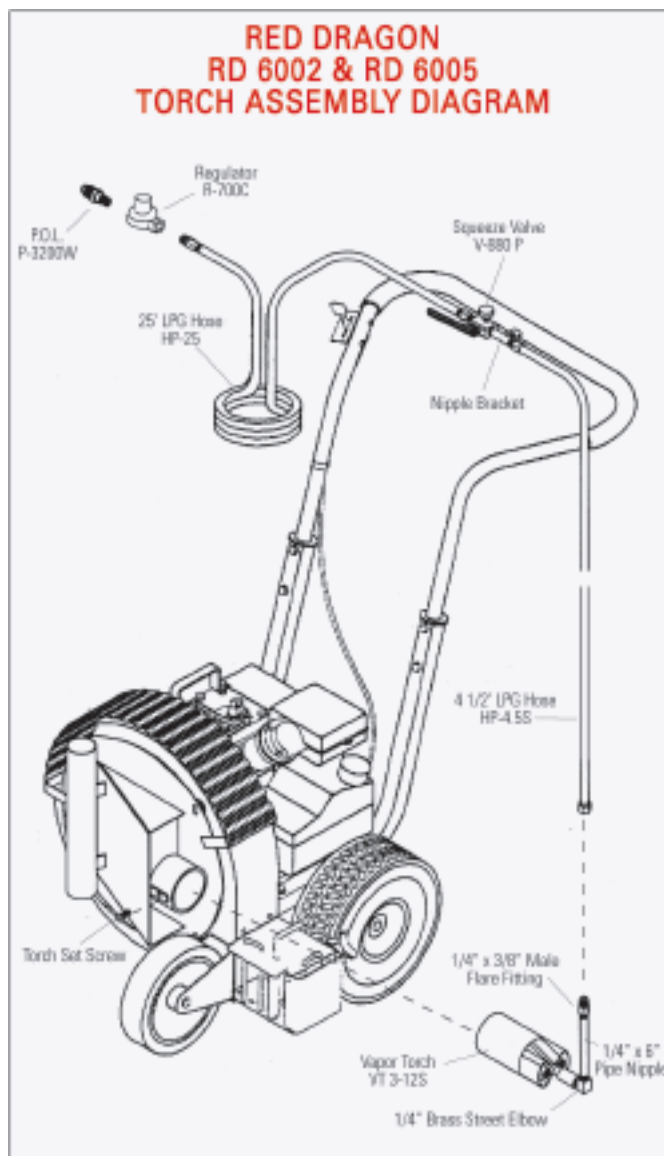

Contact Flame Engineering, Inc. for technical questions or to find the proper replacement part for your **RED DRAGON** Equipment. We have the best customer service available and we stand behind our products 100%.

800-255-2469

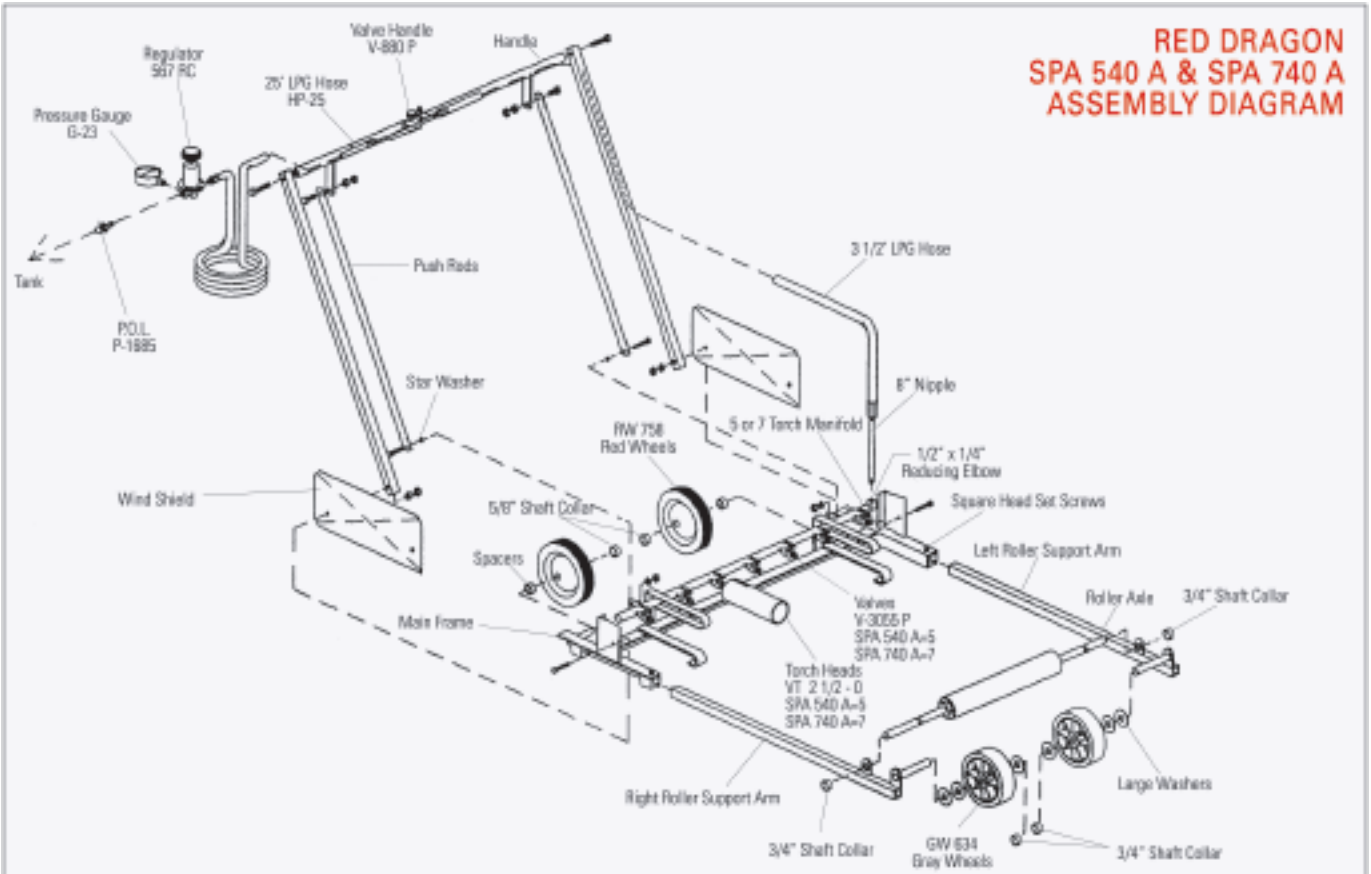
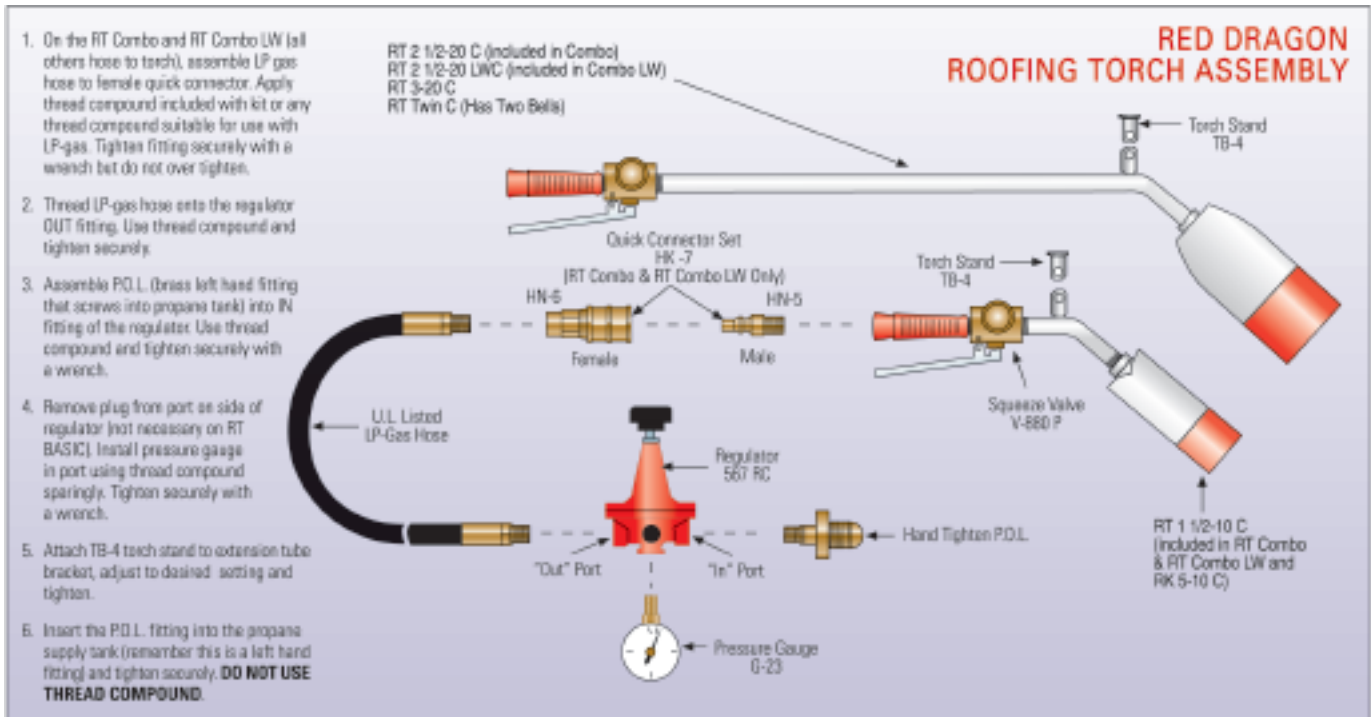

Check List For Safe LP-Gas Use

1. DO NOT use torches on or near combustible materials.
2. Inspect equipment daily.
3. Secure cylinders in a level, upright position. DO NOT invert or lay cylinders on their sides.
4. Use only vapor equipment on cylinders equipped with vapor withdrawal valves. Use only liquid equipment on cylinders designed for liquid withdrawal. DO NOT invert vapor cylinders to dispense liquid.
5. DO NOT apply flame to cylinders to increase pressure.
6. DO NOT operate torches or any equipment if the odor of LP Gas (butane/propane) is evident. Immediately shut off all valves and, using soapy water, check all equipment for leaks.
7. LP Gas (butane/propane) is heavier than air which causes it to accumulate in low areas. Check low areas for accumulation and ventilate. Be certain all work areas are well ventilated.
8. Keep torches, open flame, and sources of ignition away from cylinders, regulators, and hose.
9. Cylinder valves must be protected. DO NOT hoist cylinder by the valve.
10. Gloves should be used at all times. Long sleeves, long pants, and boots are recommended.
11. Never leave a lighted torch unattended.
12. For more detailed information, consult your local LP dealer, Flame Engineering, NPGA, NRCA, or NFPA Pamphlet 58. This information is provided as a general guide for safe LP-Gas use and in no way constitutes a complete safety program.

WARNING:
Use extreme caution at all times. You are using an intense open flame. Disregard of safe practices can result in severe fire damage, serious personal injury or death.

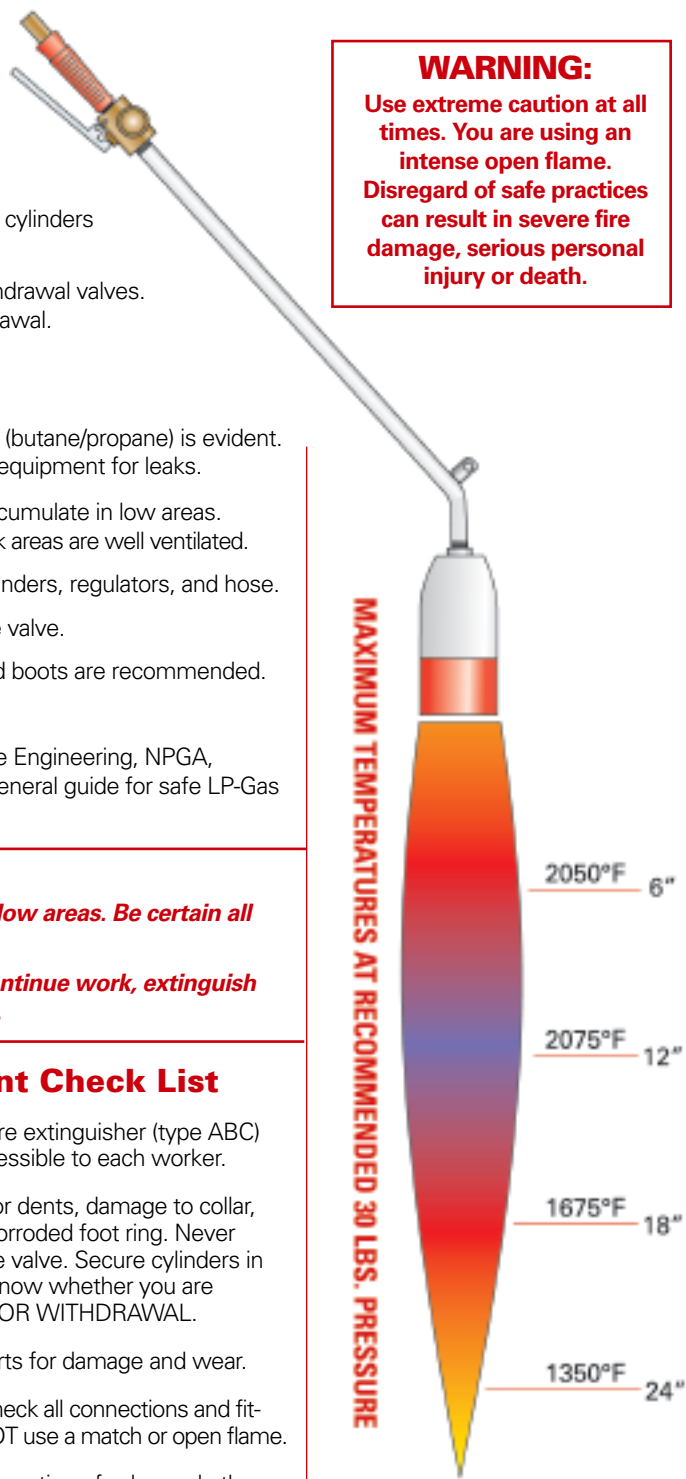

CAUTION:

Propane is heavier than air which causes it to accumulate in low areas. Be certain all areas are well ventilated.

Propane has a distinct odor. If you smell it, immediately discontinue work, extinguish all flames, find the leak and correct it.

PROPANE DATA

Properties of Propane:

Chemical Formula	C3H8
BTU per Gallon (Vaporized)	91,690
BTU per Pound	21,591
Weight per Gallon of Liquid	4.23
Vaporization Temperature	-44°F
Specific Gravity - Vapor (Air=1)	1.53
Specific Gravity - Liquid (Water=1)	0.51
Vaporization Rate (Liquid to Vapor)	272:1

Combustion Data

Limits of Flammability, % of Gas in Air	2.3% to 9.5%
Air required to burn 1 Cu Ft Vapor	23.5 Cu Ft
Oxygen required to burn 1 Cu Ft Vapor	4.9 Cu Ft
Ignition Temperature	920-1020°F
Optimum Flame Temperature	3500°F
Vapor Pressure at 0° F	28 PSI
Vapor Pressure at 70°F	122 PSI
Vapor Pressure at 100°F	190 PSI

Daily Equipment Check List

1. Be sure you have a fire extinguisher (type ABC) on the job, easily accessible to each worker.
2. Check LP cylinders for dents, damage to collar, damage to valve or corroded foot ring. Never hoist a cylinder by the valve. Secure cylinders in an upright position. Know whether you are using LIQUID or VAPOR WITHDRAWAL.
3. Visually inspect all parts for damage and wear.
4. Using soapy water, check all connections and fittings for leaks. DO NOT use a match or open flame.
5. Ignite torch. Check operation of valve and other adjustable parts.

NOTE: When extinguishing a torch, shut off cylinder valve and allow gas to burn out of lines.

Available Training Resources:

A video presentation, "On The Roof Safety With Propane Torches" is available from Flame Engineering, Inc. free of charge. Call 1-800-255-2469 to receive your FREE copy.

Additional CERTA (Certified Torch Applicator) training is available through the Midwest Roofing Contractors Association. Please contact MRCA for further information at:

Midwest Roofing Contractors Association

4840 Bob Billings Parkway • Lawrence, Kansas 66049 • Phone: 785/843-4888 • Fax: 785/843-7555 • Email: mrca@mrca.org

Order Information, Terms and Conditions

PRICING POLICY

Prices are subject to change without notice. Prices charged will be those in effect at the time of order. Please call for a current price sheet.

SELLING POLICY:

Possession of our price list or discount sheet is not an offer to sell. All orders are subject to acceptance by the home office at LaCrosse, Kansas.

WARRANTY:

We warrant all goods to be free of defects in material and workmanship. We repair or replace defective merchandise returned upon authorization. DO NOT return goods without consent. Warranty does not apply to items altered or subjected to misuse or negligence.

PRODUCT CHANGES:

Flame Engineering, Inc. is constantly at work improving products. Therefore, in order to incorporate new engineering advances, we reserve the right to alter model designs and to change weights and specifications. Flame Engineering, Inc. shall not be required to modify equipment already sold or in service.

FREIGHT POLICY:

See current price lists for freight policy. Customers from Alaska, Hawaii and foreign countries will be allowed full freight only to the embarkation point and only if other requirements are fulfilled. We reserve the right to ship the most economical way.

RESTOCKING CHARGES:

No merchandise may be returned for credit without the sellers prior approval, and only with transportation charges prepaid. A fifteen percent restocking charge will be deducted from any credit issued.

PAYMENTS:

See current price list for payment terms and conditions. The seller reserves the right to ship C.O.D. while credit is being confirmed. Payment to be made only in U.S. currency.

PAST DUE ACCOUNT:

No shipments will be made to past due accounts. A service charge will be made on all past due invoices. Please refer to current price list for specific rate.

CLAIMS, SHORTAGES, AND DAMAGE:

Any claims for shortages or goods damaged in transit must be made within 10 days after receipt of the merchandise. All claims should be made to the delivering carrier by the consignee.

IMPORTANT NOTICE:

Should a product prove to be defective or unsuitable in any way, it is understood that Seller's and Manufacturer's limit of liability for all damages, including but not limited to incidental or consequential damages, shall be to repair defective product, to provide equivalent quantity of replacement product, or to refund the purchase price.

By placing an order with FLAME ENGINEERING, INC. for RED DRAGON Products, you accept these terms and conditions.





We Stand Behind Our Products 100 Percent!

At Flame Engineering, Inc., we take pride in the quality and craftsmanship which becomes part of each and every product we manufacture. All torches are individually tested before leaving the facility to ensure safe and dependable use. In the unlikely event that you are unsatisfied with a product, for any reason, please call our toll-free number immediately and receive prompt assistance and satisfaction.

Thank you for choosing RED DRAGON Products.

800-255-2469



W. Highway 4 • P.O. Box 577 • LaCrosse, KS 67548-0577
Toll Free: 800-255-2469 • 785-222-2873 • Fax: 785-222-3619
www.FlameEngineering.com



RED DRAGON PRODUCTS ARE MANUFACTURED UNDER PATENTS:
3,357,474; 3,386,497; 4,984,515; 4,658,802; 3,147,027; 6,014,835
other patents pending.

© 2007 FLAME ENGINEERING, INC. • Printed in the U.S.A.